

COOPER LIGHTING - SURE-LITES®

DESCRIPTION

Perfect for commercial or architectural applications where the aesthetics of a fully recessed unit are essential. The slim profile of the RG1 is ideal for low ceilings and blends inconspicuously with existing recessed installations; the optional white gimbal ring offers the perfect blend for suspended ceilings. Gimbal mounted lamp provides directional aiming of units. The RG1 combines a high output sealed beam type lamp, sealed lead calcium battery and full feature Sure-Lites electronics to complete the high performance package.

Catalog #	Type
Project	
Comments	
Prepared by	Date

SPECIFICATION FEATURES

Electronic

Dual Voltage Input
120/277 VAC, 60Hz
Line-latching
Solid-state Voltage Limited Charger
Solid-state Switching
Low Voltage Disconnect
Brownout Circuit
Overload/Short Circuit Protection
Test Switch/Power Indicator Light

3/4"

Prewired Plaster Frame
White Trim Ring, with Integral Test Switch, held in place with Torsion Springs

Battery

Sealed Lead Calcium, Recombination
Maintenance Free, Long Life
Full Recharge Time, 24 hrs. (max.)
Polarized Battery Terminals

Warranty

Unit - 1 year
Battery - 5 year pro-rata

Head/Lamp Data

Adjustable Aiming Angle 30°
Glare-Free Lens
Fully Adjustable, accommodates different ceiling thicknesses
Matching Remote also available
Standard Black Gimbal Ring, Optional White Gimbal Ring available
Fixture illuminates upon loss of AC power only (normally off)

Housing Construction

20 Gauge Die-Stamped Steel
Polycarbonate Lens Included
Hanger Bars accommodate 24" spans
Hanger Bars can be Rotated 90° on Plaster Frame
Conduit Knockouts, four 1/2" and two

Code Compliance

IC Rated
UL 924 Listed
CSA Certified
Life Safety NFPA 101
NEC/OSHA
Most State and Local Codes



RG1 SERIES

RECESSED GIMBAL
EMERGENCY LIGHT

Emergency Lighting

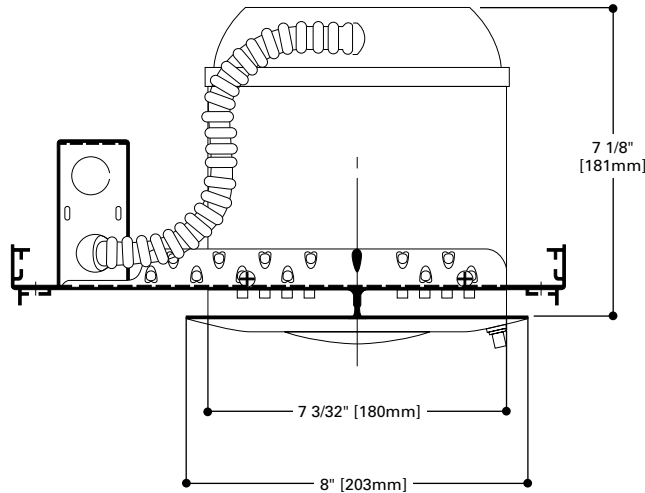

ELECTRICAL RATINGS

Model	Rated Wattage to 87 1/2% of Rated D.C. Voltage					Lamp Information		
	DC Voltage	1 1/2 Hours	2 Hours	3 Hours	4 Hours	Type	Wattage	Number
RG1	6	10.8	7.2	-	-	Incandescent	9	29-84

ENERGY DATA

Input Current (Max.):
120V= .12A
277V= .05A



ORDERING INFORMATION

SAMPLE NUMBER: RG1WH

RG1	Options (add as suffix)	Accessories (order separately)
Model Number RG1	BK=Black Gimbal Ring/Black Baffle WH=White Gimbal Ring/White Baffle Alternate Lamps: consult Cooper Lighting Representative Other Options: consult Cooper Lighting Representative	WG1=Wire Guard

PHOTOMETRICS

Horizontal Distribution

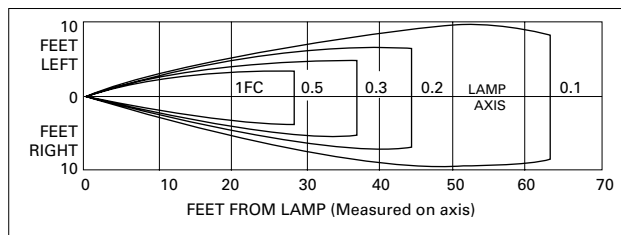

Lamp No. 29-84
Initial Lumens – 29-84 @ 132

Vertical Distribution

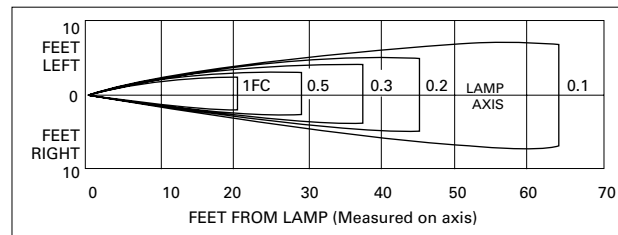

Lamp No. 29-84

TECHNICAL DATA

Lamps

Designed specifically for emergency lighting applications, the PAR 36 sealed beam type design insures optimum glare-free trapezoidal light distribution along with horizontal and vertical adjustment by rotating the lens within the gimbal ring. Lamps illuminate upon loss of AC power only (fixture is normally off).

Housing

The rugged 20 gauge die-stamped cold rolled steel housing is finished with an attractive white corrosion-resistant polyester powder coat paint. The housing adjusts in the plaster frame 1 3/8" to accommodate different ceiling thickness. The IC Rated housing is engineered for use in insulated ceilings and is completely prewired. The junction box is not rated for through wiring. Gimbal trim ring is finished with a white baked acrylic enamel and provides up to 40° vertical adjustment and can rotate 358°. Polarized mox connectors simplify wiring connections between trim ring and housing.

Line-Latched

Sure-Lites' line-latched electronic circuitry makes installation easy and economical. A labor efficient AC-activated load switch prevents the lamps from turning on during installation to a non-energized AC circuit. Line-latching eliminates the need for a contractor's return to a job site to connect the batteries when the building's main power is permanently turned on.

Solid-State Charger

Supplied with a 120/277 VAC, voltage regulated solid-state charger. Immediately upon restoration of AC current after a power failure, the charger provides a high charge rate. The charge circuit reacts to the condition of the battery and alters the rate of charge in order to maintain peak battery capacity and maximize battery life. Solid-state construction recharges the battery following a power failure in accordance with UL 924.

Overload and Short Circuit Protection

The solid-state overload monitoring device in the DC circuit disconnects the lamp load from the battery should excessive wattage demands be made and automatically resets when the overload or short circuit is removed. This overload current protective feature eliminates the need for fuses or circuit breakers for the DC load.

Brownout Circuit

The brownout circuit in Sure-Lites' units monitors the flow of AC current to the unit and activates the emergency lighting system when a predetermined reduction of AC power occurs. This dip in voltage will cause most ballasted fixtures to extinguish causing loss of normal lighting even though a total power failure has not occurred.

Solid-State Transfer

The unit incorporates a solid-state switching transistor which eliminates corroded and pitted contacts or mechanical failures associated with relays. The switching circuit is designed to detect a loss of AC voltage and automatically energizes the lamps. Upon restoration of the AC power, the emergency lamp will switch off and the charger will automatically recharge the battery.

Low Voltage Disconnect

When the battery's terminal voltage falls below 80% of the rated voltage, the low voltage circuitry disconnects the lighting load. The disconnect remains in effect until normal utility power is restored, preventing deep battery discharge.

Test Switch/Power Indicator Light

Conveniently located Test Switch allows for manual verification of proper operation of the transfer circuit and emergency lamps. The Power Indicator Light provides visual assurance that the AC power is on.

Sealed Lead Calcium Battery

The fully sealed, long life, maintenance free lead calcium battery is ideal for emergency lighting applications. These recombinant cycle batteries typically provide eight to ten years of life and may be operated in any position.

Warranty

All Sure-Lites' units are backed by a firm one year warranty against defect in material and workmanship (excluding lamps). Maintenance free, long life, sealed lead calcium batteries carry a five-year pro-rata warranty.