

PHILIPS bodine B33

INSTALLATION INSTRUCTIONS

! IMPORTANT SAFEGUARDS !

WHEN USING ELECTRICAL EQUIPMENT, BASIC SAFETY PRECAUTIONS SHOULD ALWAYS BE FOLLOWED, INCLUDING THE FOLLOWING:

READ AND FOLLOW ALL SAFETY INSTRUCTIONS

1. To prevent high voltage from being present on red, yellow, yellow/black, and yellow/red output leads prior to installation, inverter connector must be open. Do not join inverter connector until installation is complete and AC power is supplied to the emergency ballast.
2. This product is for use with two or three 32 W (4') T8 fluorescent lamps, two or three 36/39 W or two 40 W to 55 W (4-pin) long compact fluorescent lamps without integral starters.
3. Make sure all connections are in accordance with the National Electrical Code and any local regulations.
4. To reduce the risk of electric shock, disconnect both normal and emergency power supplies and inverter connector of the emergency ballast before servicing.
5. This emergency ballast is for factory or field installation.
6. This product is for use in indoor fixtures except air handling heated air outlets, and wet, damp, or hazardous locations.
7. An unswitched AC power source is required. (120 or 277 VAC)
8. Do not install near gas or electric heaters.
9. The battery is field replaceable. Contact manufacturer for information on replacements. Use caution when replacing battery. Dispose of battery properly. Do not incinerate.
10. The use of accessory equipment not recommended by the manufacturer may cause an unsafe condition.
11. Do not use this product for other than intended use.
12. Servicing should be performed by qualified service personnel.

SAVE THESE INSTRUCTIONS



**CONTAINS NICKEL-CADMIUM
RECHARGEABLE BATTERY.
MUST BE RECYCLED OR
DISPOSED OF PROPERLY.**



01/27/09

© Philips Emergency Lighting

A Division of Philips Electronics North America Corporation

236 Mt. Pleasant Rd. • Collierville, TN USA 38017-2752 • Tech Support 888-263-4638 • Fax 901-854-1630 • www.philips.com/bodine
73000033

INSTALLATION



WARNING: TO PREVENT HIGH VOLTAGE FROM BEING PRESENT ON RED, YELLOW, YELLOW/BLACK, AND YELLOW/RED OUTPUT LEADS PRIOR TO INSTALLATION, INVERTER CONNECTOR MUST BE OPEN. DO NOT JOIN INVERTER CONNECTOR UNTIL INSTALLATION IS COMPLETE AND AC POWER IS SUPPLIED TO THE EMERGENCY BALLAST.

NOTE: Before installing the emergency ballast, make sure that the necessary branch circuit wiring is available. An unswitched source of power is required. The emergency ballast must be fed from the same branch circuit as the AC ballast.

1. Disconnect AC power from the fixture. Remove the ballast channel cover and install the emergency ballast either on top of the fixture (see Illustration 1) or remote from the fixture up to 1/2 the distance the AC ballast manufacturer recommends removing the AC ballast from the lamp, or up to 50 feet, whichever is less (see Illustration 3).
2. Select the appropriate wiring diagram to connect the emergency ballast to the AC ballast and lamp. Make sure all connections are in accordance with the National Electrical Code and any local regulations.
3. Install the test switch through the ballast channel cover of a troffer or through the side of a strip fixture. Drill a 1/2" hole and install the switch as shown (see Illustration 4). Wire the test switch so that it removes AC power from both the emergency ballast as shown in Illustration 2.
4. Refer to Illustration 4 and install the charging indicator light. Connect charging indicator light to emergency ballast by matching violet and brown leads.
5. In a readily visible location, attach the label "CAUTION-This Unit Has More Than One Power Connection Point. To Reduce The Risk Of Electric Shock, Disconnect Both The Branch Circuit-Breakers Or Fuses And Emergency Power Supplies Before Servicing."

ILLUSTRATION 1

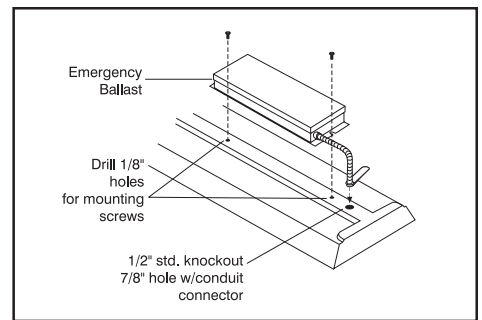

ILLUSTRATION 2

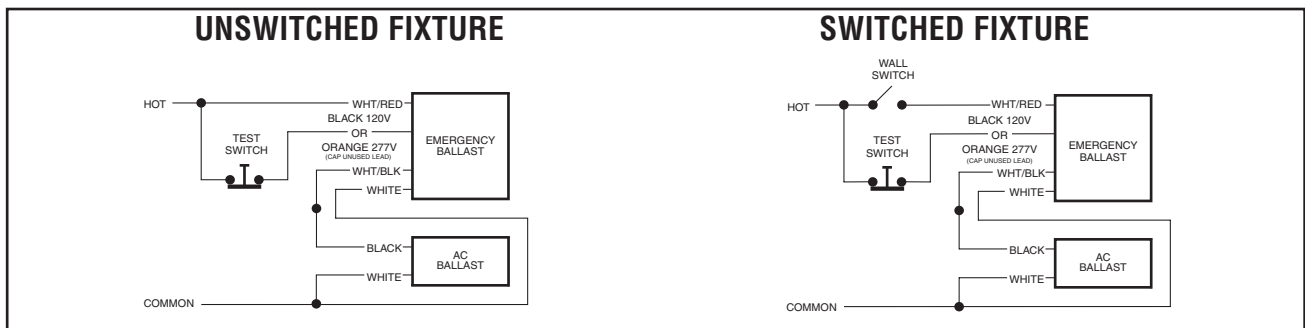
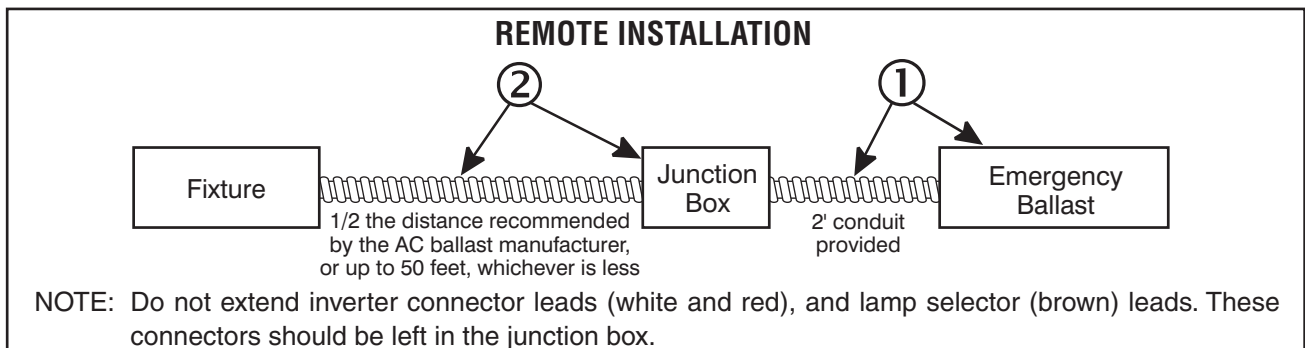
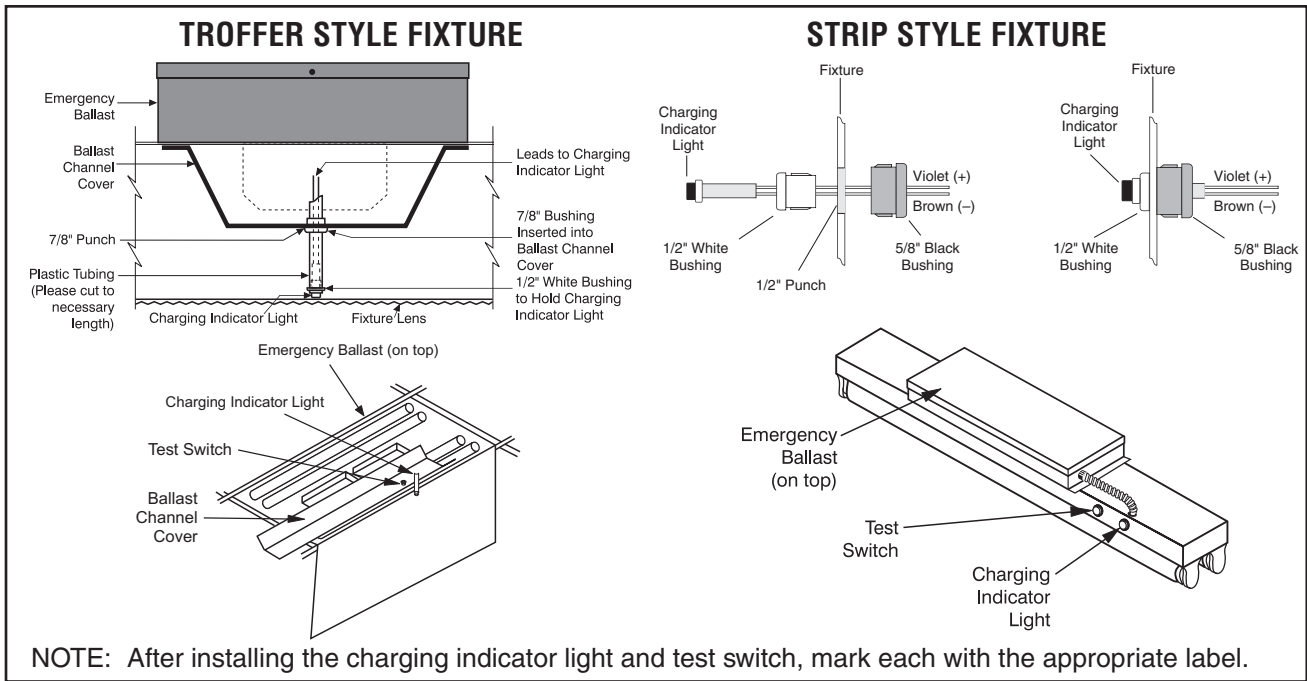

ILLUSTRATION 3



- ① Emergency ballast with flexible conduit.
- ② Conduit and junction box (not supplied), but necessary for remote installation.

ILLUSTRATION 4



6. After installation is complete, supply AC power to the emergency ballast and join the inverter connector.
7. A short-term discharge test may be conducted after the emergency ballast has been charging for one hour. Charge for 24 hours before conducting a long-term discharge test. Refer to OPERATION.

OPERATION

When AC power is applied, the charging indicator light is illuminated, indicating that the battery is being charged. When power fails, the emergency ballast automatically switches to emergency power, operating either two or three lamps for at least 90 minutes.

MAINTENANCE

Although no routine maintenance is required to keep the emergency ballast functional, it should be checked periodically to ensure that it is working. The following schedule is recommended:

1. Visually inspect the charging indicator light monthly. It should be illuminated.
2. Test the emergency operation of the fixture at 30-day intervals for a minimum of 30 seconds. Either two or three lamps should operate at reduced illumination.
3. Conduct a 90-minute discharge test once a year. Either two or three lamps should operate for at least 90 minutes.
4. The life expectancy of the battery is 7 to 10 years. If the battery fails to provide 90 minutes of illumination, it should be replaced.

CAUTION: To replace battery, disconnect inverter connector and both switched and unswitched AC power from the fixture. Remove two screws (located on each end of lid), remove lid, and unplug and remove old battery. Plug in new battery, place inside ballast case, then replace lid and two screws. Supply AC power to fixture and reconnect inverter connector. Charging light should be illuminated. Contact manufacturer for battery replacement.

REFER ANY SERVICING INDICATED BY THESE CHECKS TO QUALIFIED PERSONNEL.

WIRING DIAGRAMS

The following diagrams are typical schematics only. May be used with other ballasts. Consult the factory for other wiring diagrams. Emergency Ballast and AC Ballast must be fed from the SAME BRANCH CIRCUIT.



CAUTION: B33 IS FOR USE WITH INSTANT START PARALLEL AC BALLASTS ONLY.

EMERGENCY BALLAST AND AC BALLAST MUST BE FED FROM THE SAME BRANCH CIRCUIT.

TYPICAL SCHEMATICS ONLY. MAY BE USED WITH OTHER BALLASTS. CONSULT THE FACTORY FOR OTHER WIRING DIAGRAMS

WIRING DIAGRAMS for 3-LAMP emergency operation

A. THREE (3) LAMP INSTANT START PARALLEL BALLAST

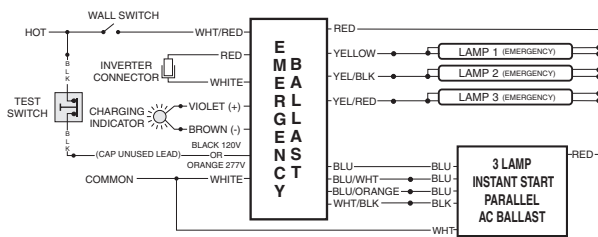

B. THREE (3) LONG COMPACT LAMP INSTANT START PARALLEL BALLAST

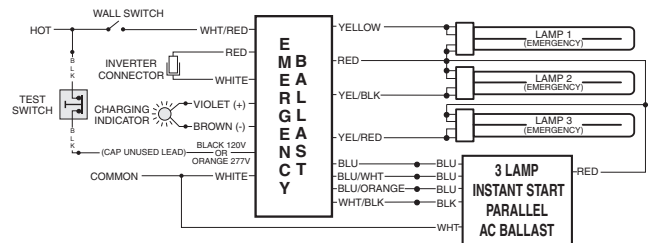

EMERGENCY BALLAST AND AC BALLAST MUST BE FED FROM THE SAME BRANCH CIRCUIT.
 TYPICAL SCHEMATICS ONLY. MAY BE USED WITH OTHER BALLASTS. CONSULT THE FACTORY FOR OTHER WIRING DIAGRAMS

WIRING DIAGRAMS for 2-LAMP emergency operation

C. TWO (2) LAMP INSTANT START PARALLEL BALLAST

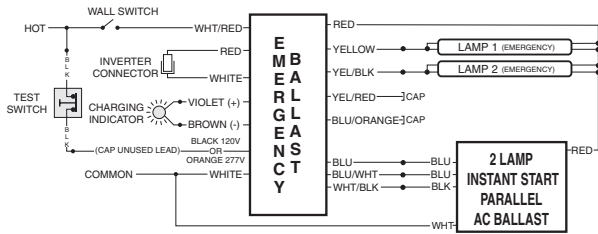

D. THREE (3) LAMP INSTANT START PARALLEL BALLAST

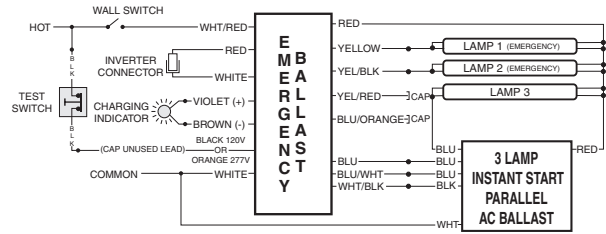

E. FOUR (4) LAMP INSTANT START PARALLEL BALLAST

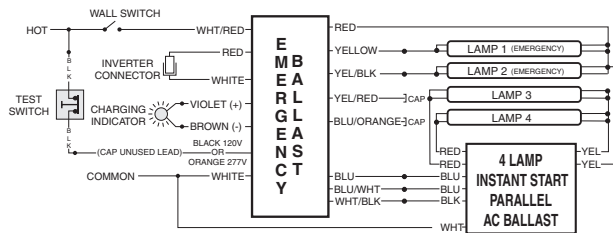

F. TWO (2) LONG COMPACT LAMP INSTANT START PARALLEL BALLAST

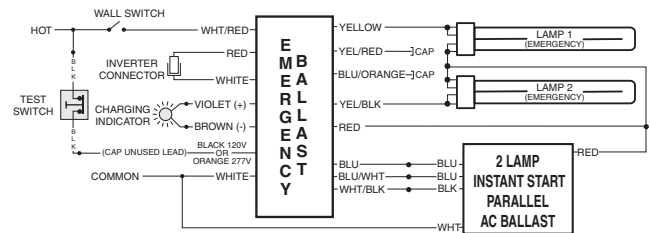

CAUTION: B33 IS FOR USE WITH INSTANT START PARALLEL AC BALLASTS ONLY.

WIRING DIAGRAMS for Emergency-Only fixtures

G. TWO (2) LAMPS WITHOUT AC BALLAST

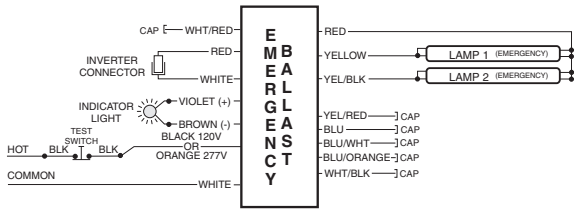

H. THREE (3) LAMPS WITHOUT AC BALLAST

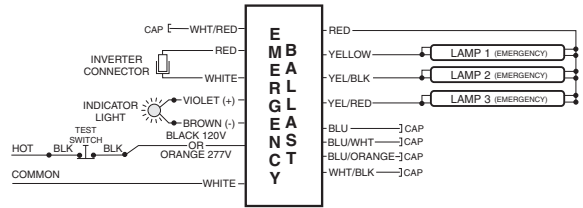

I. TWO (2) LONG COMPACT LAMPS WITHOUT AC BALLAST

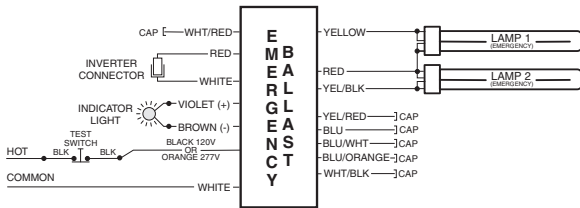

J. THREE (3) LONG COMPACT LAMP WITHOUT AC BALLAST

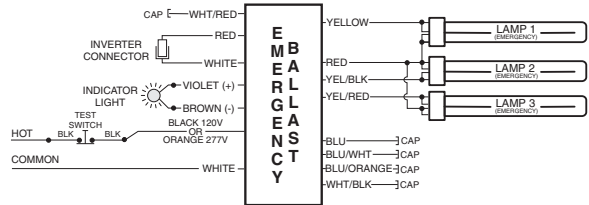

CAUTION: B33 IS FOR USE WITH INSTANT START PARALLEL AC BALLASTS ONLY.