



Renaissance Series - CEL-B



PROJECT: _____
 FIXTURE TYPE: _____
 LOCATION: _____
 CONTACT/PHONE: _____

CEL Surface Mount Edge-Lit LED Exit Sign Battery Back-up

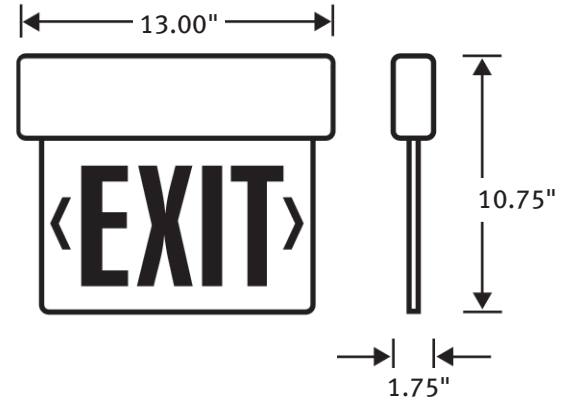

PRODUCT DESCRIPTION

Renaissance Series Surface Mount Edge-Lit LED Exit Signs offer long lamp life, energy efficiency and uniform illumination. The premium architectural design of the edge-lit construction has made this the specification choice for exit signage. The unique field-applied chevron directional indicators make the Renaissance Series the most uncomplicated edge-lit sign to specify. Surface mount construction makes it easy to enjoy the aesthetic benefits of edge-lit design with simple J-box mounting.

PRODUCT SPECIFICATIONS

CONSTRUCTION

Crystal clear acrylic face panel – Mirrored divider provided on double face signs to simulate clear appearance – Extruded aluminum housing – Includes die cast aluminum canopy for top, back or end mounting – Pre-drilled canopy attachment locations with easily removed hole covers – 6” letters with 3/4” stroke width – Full-size, 3/4” wide chevron directional indicators – Field-applied chevron directional indicators with preapplied installation template – Red or green letters – Available in white, black or anodized aluminum finish.

ELECTRICAL

Dual voltage 120/277VAC.

LAMPS

Long life, energy saving, ultra-bright LED lamps – Red or green LED/letters – Red signs consume less than 4 watts – Green signs consume less than 3 watts – LEDs are connected in a series/parallel configuration such that the unlikely failure of one LED will affect no more than one other LED.

BATTERY

Sealed, maintenance-free lead calcium – Battery will operate sign for a minimum of 90 minutes in the event of a power outage.

CODE COMPLIANCE

UL Listed – ETL Listed – NFPA 101 Life Safety Code compliant – NEC and OSHA compliant – Meets the State of Minnesota energy efficiency requirements

WARRANTY

5-year warranty.

Product specifications subject to change without notice.

INSTALLATION

MOUNTING

May be top, back or end mounted – All signs include die cast aluminum canopy and mounting hardware for easy top, back or end mount installation.

ENGINEERING DATA

	INPUT VOLTS	MAX. AMPS	MAX. WATTS	STANDBY WATTS*
Red LED	120	0.15	3.7	3.7
Red LED	277	0.13	3.2	3.2
Green LED	120	0.14	2.8	2.8
Green LED	277	0.13	2.6	2.6

* Fully charged battery.

BATTERY DATA

TYPE	BATTERY VOLTAGE	SHELF LIFE ¹	EXPECTED LIFE ¹	TEMPERATURE RANGE ²
Lead Calcium	6V, 2.3Ah	6 months	5-8 years	40°F-95°F

1At 77oF

2To obtain rated life capacity.

-Lead Calcium battery warranted for one full year with additional 4 years pro-rated warranty-Nickel Cadmium battery warranted for five years with an additional 5 years pro-rated warranty-Recharges in 24 hours or less

ORDERING INFORMATION

SERIES	FACES	LETTER COLOR	FINISH
CEL-B = Surface Mt Edge-Lit	1 = Single Face	R = Red Letters	WH = White
LED Exit Sign-Battery Back-Up	2 = Double Face	G = Green Letters	BL = Black
			BA = Brushed Aluminum

Ordering Example: CEL-2-B-R-W-RMK