



CL Series

Concealed Recessed Emergency Luminaire

Catalog Number	
Comments	Type

FEATURES

Application

The CL series is a recessed, self-contained emergency light with fully automatic operation suitable for wall or ceiling mount applications. With its high wattage lamp offering it offers concealed and unobtrusive emergency lighting compliance for small and large open floor-plans. Two flat panel doors are flush with trim and mounting surface. Upon loss of power, the doors automatically open and reveal the emergency lighting lamp-heads.

Construction

Back-box made of galvanized 20 gauge steel. Galvanized bar hangers span up to 30" on center. Trim and door panels in durable white powder coat finish. Can be wall-papered or field painted. Trim and panel doors are mounted flush with surface with no exposed hardware.

Installation

Wall or ceiling mount. The CL is fully recessed by means of a steel back-box complete with fully adjustable mounting hardware. The modular assembly and quick connector design allow for fast and easy installation. T-bar clips secure unit to grid in ceiling mount applications. Rough-in dimensions: 13.5" X 6.75", allow 5.5" for panel opening clearance.

Illumination

The CL series provides illumination with two adjustable 12 through 75 watt MR-16 Halogen lamps rated for 2,000 hours of operation. Soft start lamp circuit allows for extended lamp life.

Compliances

UL 924 Listed to 924 Standard
 NFPA 101 Life Safety Code
 NFPA 70 National Electrical Code
 OSHA

Warranty

Full three-year warranty.

12-Volt, self-diagnostic with time-delay, sealed lead-calcium or NiCad battery with remote capacity



ACCESSORIES Order Separately

Part Number	Description
CLRI	Remote Diagnostic Indicator
CLRT	Remote Testing Transmitter
CLRK	Rough-in Kit
CPCLRK	Chicago Plenum Listed Rough-in Kit

ORDERING GUIDE

CL	50	N	H20	-CP
Series	Capacity	Battery Type	Lamp Wattage	Options
	50 - 50 Watts ¹ 100 - 100 Watts ² 150 - 150 Watts	Blank - Lead Calcium N - Nickel-Cadmium	H12 - 12 Watt Halogen H20 - 20 Watt Halogen H35 - 35 Watt Halogen H50 - 50 Watt Halogen H75 - 75 Watt Halogen	-CP - Chicago Plenum Rated ⁴ -XK - Less Rough-in Kit ³

¹ Not available with H35, H50, or H75 lamps

² Not available with H75 lamps

³ To order the rough-in kit only for early installation, add "-XK" option suffix to CL model number and order "CLRK" separately.

⁴ For Chicago Plenum rated, order CL model number plus "-XK-CP" and order the "CPCLRK" separately.





CL Series

Concealed Recessed Emergency Luminaire

SPECIFICATIONS

Electronics

Dual-voltage input of 120/277VAC. Precision controlled motor and cam system ensures smooth and reliable opening and closing of light source. LED indicator provides visible fault detection and AC-On indication. Test switch provides manual activation of a 30-second diagnostic test.

Standard Features Include:

- Self-test, self-diagnostics monitors lamp load transfer circuit, battery capacity, operation and motor drive. 28 day self-test.
- Brownout protection
- Low voltage disconnect prevents deep discharge of the battery
- Voltage polarity protected by use of polarized connector
- 15 minute time delay re-transfer
- Fused remote leads for units with remote capacity

Optional Accessories

CLRT- Remote IR Testing Transmitter. Selectable 30-second or 90-minute remote testing. Only one required for multiple units.

CLRI- Remote Diagnostic Indicator Display.

Operating Temperature Range

Lead Calcium Battery: 16°C to 32°C (60°F to 90°F)

Nickel Cadmium Battery: 0°C to 38°C (32°F to 100°F)

Overall Size: 16" L X 13.5" W X 4" D

Weight: 23-31 lbs. depending upon capacity

REMOTE CAPACITY CHART

Part Number	Run Time ¹	Remote Capacity	Remote Watts ²
CL50H12	3.0 Hours	Yes	26
CL50NH12	3.0 Hours	Yes	26
CL50H20	2.0 Hours	No	--
CL50NH20	2.0 Hours	No	--

CL100H12	6.0 hours	Yes	76
CL100NH12	6.0 Hours	Yes	76
CL100H20	4.0 Hours	Yes	60
CL100NH20	4.0 Hours	Yes	60
CL100H35	2.0 Hours	Yes	30
CL100NH35	2.0 Hours	Yes	30
CL100H50	1.5 Hours	No	--
CL100NH50	1.5 Hours	No	--

CL150H12	9.0 Hours	Yes	126
CL150NH12	9.0 Hours	Yes	126
CL150H20	6.0 Hours	Yes	110
CL150NH20	6.0 Hours	Yes	110
CL150H35	4.0 Hours	Yes	80
CL150NH35	4.0 Hours	Yes	80
CL150H50	2.0 Hours	Yes	50
CL150NH50	2.0 Hours	Yes	50
CL150H75	1.5 Hours	No	--
CL150NH75	1.5 Hours	No	--

¹Unit battery run time for integral lamps only (no remote lamps connected).

²Max. watts available for connection of remote lamps at 1.5 Hour unit minimum run time.

SUGGESTED CENTER-TO-CENTER SPACING

Lamp	Type	Ceiling Height			
		10'	12'	16'	20'
H12	12W Halogen	17'	17'	16'	16'
H20	20W Halogen	36'	36'	34'	34'
H35	35W Halogen	65'	65'	58'	64'
H50	50W Halogen	70'	70'	70'	70'
H75	75W Halogen	130'	140'	134'	140'

Based on minimum illuminance of 0.1FC and average illuminance of 1.0FC. Assumes fixture is ceiling mounted in a 200' W X 200' L open space with reflectance of 80/50/20.

DIMENSIONS

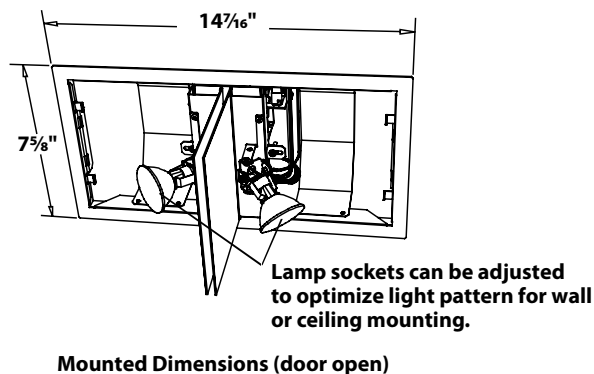
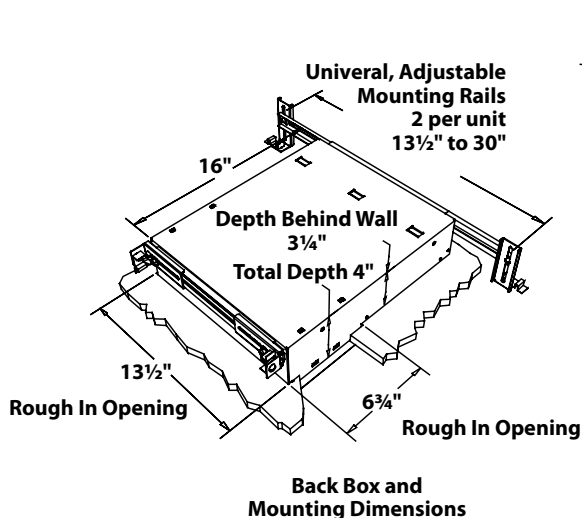

Dual-Lite • www.dual-lite.com

A Hubbell Lighting, Inc. brand with representatives' offices in principal cities throughout North America.

Copyright © Hubbell Lighting, Inc., All Rights Reserved • Specifications subject to change without notice. • Printed in U.S.A.

0603443A 8/09