



# PWL12V28 VRLA Battery

## Valve Regulated Lead Acid Battery

Our patented PWL Valve Regulated Lead Acid Battery is designed for telecom and CATV back-up applications.

### Specifications

- Top access design, available distributed power wire harness
- Grid Alloy: Lead Calcium Tin
- Case/Cover: PPE Resin (Flame Retardant, UL94 V-0, Halogen Free)
- Terminal: M5 Nut, Copper Terminal

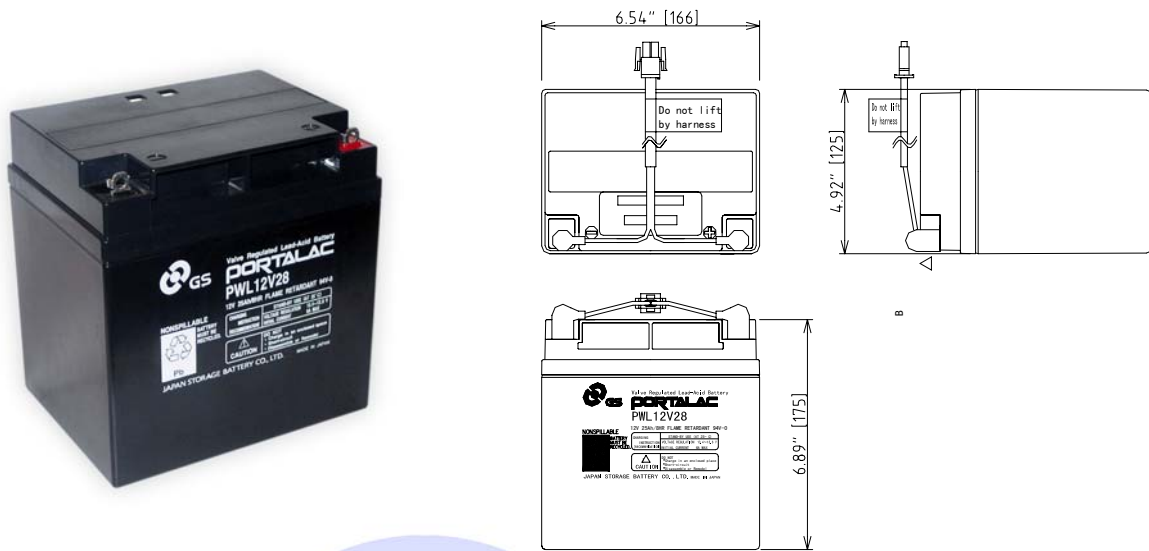

Model	Nominal Voltage (V)	Capacity 8HR (Ah)	Mass	Design Life @ 25 deg. C. (Year)	Dimensions			
					L	W	H	TH
PWL12V28	12	25	19.6lb 8.9kg	13	6.54" 166mm	4.92" 125mm	6.89" 175mm	6.89" 175mm

PWL12V28 Amperes to Final Volts per Cell Temp.: 25 deg. C. ( 77F)											
		Discharge Time (hr)									
F.V.	20	20	10	9	8	7	6	5	4	3	2
1.75	1.4	2.2	2.5	2.7	3.1	3.4	3.8	4.4	5.3	6.8	9.50
1.80	1.3	2.1	2.4	2.6	2.9	3.2	3.7	4.3	5.1	6.5	10.6
1.85	1.2	2.0	2.2	2.4	2.7	3.0	6.4	4.0	4.8	6.0	9.7

Contact : **9a Yf[ YbWn QH' Gyfj JW 7 YbHyf**  
 2525 Nevada Ave N Suite #308  
 Golden Valley, MN 55427

Phone (763) 542-3155  
 Toll Free 1-800-521-4045

[www.Portalac.com](http://www.Portalac.com)