

Description

Clear, high impact shields provide an added measure of protection in areas where equipment may be subject to tampering, abuse or potential environmental factors.

Application

VERS Series shields are easily installed over most emergency lighting units, AC only or self-contained exit signs, as well as remote accessories, fixtures or lighting heads to provide additional protection against tampering, abuse or environmental factors.

Construction

The VERS Series is produced in clear, UV stable, high impact polycarbonate material. The model VERS-4X includes a 1/4" thick neoprene watertight gasket. (Mounting hardware not included.)

Product Information

VERS Series shields are available for use with:

Emergency Lighting Units

PMD-2-DL, XC-1, HL-80, HL-90/100, HL-95/105, HL-High Capacity, NB, SU/HSU and SU/HSU-FR Series

Exit Signs (Wall Mount Only, No Power Packs or Lighting Heads)

P-5, High Glow, APS, SLED, LED-APS, APA, ALED, LED-APA, ZBLED, ZC, ZCLED and FLXT Series

PCS-1 Series shields are available for use with:

Exit Signs (Wall Mount Only, No Power Packs or Lighting Heads)

APS, SLED, LED-APS, APA, ALED, LED-APA, ZBLED, ZC, ZCLED and FLXT Series



Ordering Guide

Model No.	Description
VERS	Vandal/Environmental Shield
VERS-4X	Gasketed Vandal/Environmental Shield
PCS-1	Low Profile Vandal/Environmental Shield

NOTE: All product specifications shown are subject to change without notice.

Dimensions

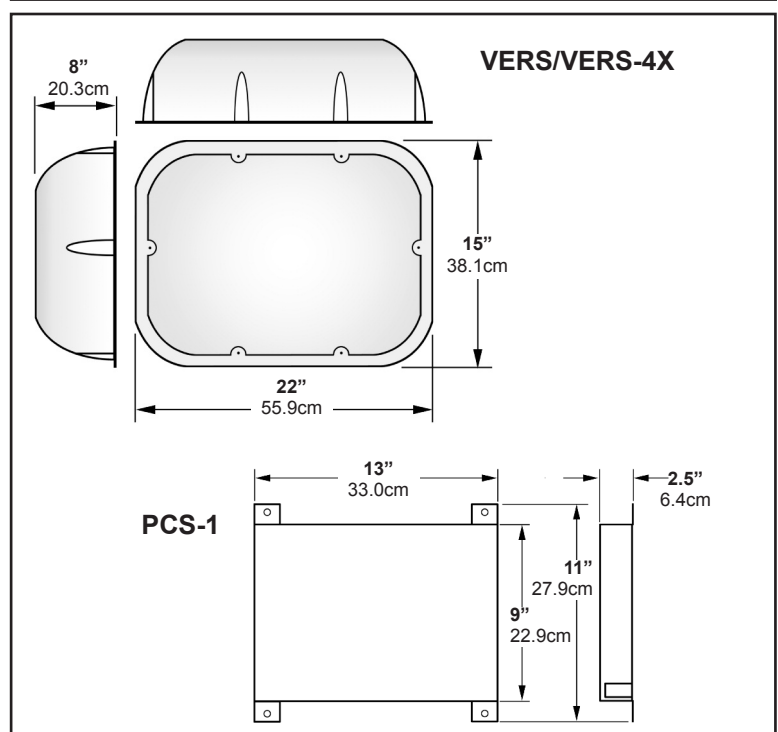

Specifier Reference

Project: _____

Fixture Type: _____

Model No.: _____

Comments: _____