

GENERAL DESCRIPTION

The CF1400-4PT converts switched and unswitched fluorescent lighting into code required emergency lighting. The CF1400-4PT may be installed in or near the fixture to provide unobtrusive life safety protection and is fully compatible with AC ballast equipped with end of lamp life circuitry.

ILLUMINATION

The CF1400-4PT provides 90 minutes of emergency illumination by utilizing existing fluorescent lighting and provides a 1400 lumen maximum output. The CF1400-4PT can be used with most 18-57W 4-pin twin, quad, and triple tube compacts and 18-55W long compact fluorescent lamps. The CF1400-4PT is compatible with standard energy-saving or electronic ballasts. See lamp operation for specific lamp types.

APPLICATION

The CF1400-4PT is suitable for commercial locations where emergency lighting protection is required using existing fluorescent lighting.

DIMENSIONS

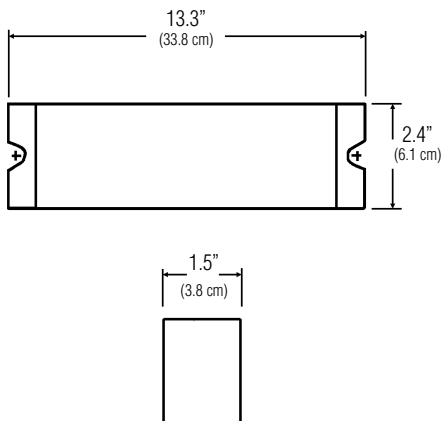

Dimensions are approximate and subject to change.

CF1400-4PT

Fluorescent Emergency Ballast

For One or Two Lamp Emergency Operation

1400 Lumen Maximum Output



HOUSING

Housing constructed of 20 gauge steel with a high temperature powder coat paint finish.

Housing allows for housing frame mounting on most recessed luminaires.

ELECTRONICS

120/277 VAC dual voltage input with surge protected, solid-state charging circuitry provides for a reliable charging system.

Charging system is complete with AC indicator lamp and test switch.

An integral time delay circuit provides compatibility with AC ballasts capable of detecting end of lamp life. The time delay circuit causes a 3 to 5 second delay when switching back to AC operation preventing the AC ballast from shutting down under false conditions.

BATTERY

Maintenance free, sealed nickel cadmium battery. Supplies 90 minutes of emergency power. Estimated service life of 10 years. Fully compatible with AC ballast equipped with end of lamp life circuitry. IEC 61951-1 Life Testing compliant.

LAMP OPERATION¹

Operates the following lamp types:²
Compact 4-pin fluorescent
Long compact fluorescent



SHOWN: CF1400-4PT

OPERATING TEMPERATURE RANGE

Standard Models: 32°F (0°C) to 131°F (55°C)
Cold Weather Option: 5°F (-15°C) to 131°F (55°C)

CODE COMPLIANCE

UL 924 listed
NFPA 70 and NFPA 101, NEC, BOCA, OSHA and IBC illumination standards
IEC 61951-1 Life Testing compliant

ELECTRICAL SPECIFICATIONS

Input power requirements

120 VAC, 60Hz, 0.29A
277 VAC, 60Hz, 0.10A

WARRANTY

Two year full electronics warranty
Two year full battery warranty

NOTES:

- 1) Consult factory for compatibility, operation and performance of product with lamp types not listed.
- 2) See table 1 on back for specific lamp performance and operation.

ORDERING INFORMATION (EXAMPLE: CF1400-4PTDL)

CF1400-4PT

FLUORESCENT EMERGENCY BALLAST

CF1400-4PT = 1400 Lumen Max. Output
Fluorescent Emergency Ballast for One Lamp Operation

OPTIONS

DL = Damp Location Listing
CW = Cold Weather Rating
5°F (-15°C) to 131°F (55°C)
including Damp Location Listing

Specification Data for CF1400-4PT Fluorescent Emergency Ballast

HOUSING

Housing constructed of 20 gauge steel with a high temperature powder coat paint finish.

Housing is very compact, thus allowing for housing frame mounting on most recessed luminaires.

ELECTRONICS

Dual voltage 120/277 VAC input is standard.

An indicator light and test switch are available to signify that AC utility is present, and periodically transfer to emergency operation.

Battery charging circuitry is entirely solid-state, and of a constant current design. Battery recharge time after a complete discharge is less than the required UL 924 standard.

Solid-state circuitry causes an instantaneous transfer to battery power if either the loss of AC utility, or a brownout condition is detected. When line voltage is present and stabilized, the transfer circuitry switches back to normal operation and begins recharging the battery. The transfer circuitry can be tested via a momentary test switch installed on the luminaire, or in a remote location.

An integral time delay circuit provides compatibility with AC ballasts capable of detecting end of lamp life. The time delay circuit causes a 3 to 5 second delay when switching back to AC operation preventing the AC ballast from shutting down under false conditions.

BATTERY

Sealed, maintenance free nickel cadmium battery is equipped with a quick connect plug assembly for easy installation.

Standard sustained emergency operation is for 90 minutes with the illumination source providing full light output.

The tested operating temperature range for the CF1400-4PT is 32°F (0°C) to 131°F (55°C) and should provide a service life of 10 years. A cold weather option is available and is tested for conditions ranging from 5°F (-15°C) to 131°F (55°C).

ELECTRICAL SPECIFICATIONS

Input power requirements

120 VAC, 60Hz, 0.29A
277 VAC, 60Hz, 0.10A

CODE COMPLIANCE

The CF1400-4PT meets or exceeds all performance standards as required by UL 924, NFPA 70, NFPA 101, NEC, BOCA, OSHA and IBC. IEC 61951-1 Life Testing compliant.

LAMP OPERATION AND PERFORMANCE

Table 1

LAMP TYPE	WATTAGE	BASE TYPE	NON-EMERGENCY MAX. LUMEN OUTPUT	EMERGENCY OP. MAX. LUMEN OUTPUT	EMERGENCY LAMP OPERATION
Long Compact	18-39	2G11/4 Pin	1250-2850	950-1100	One or Two
Long Compact	40-55	2G11/4 Pin	3000-4000	1000-1100	One
Compact	13-32	G24Q/4 Pin	900-2400	500-900	One or Two
Compact	42, 57	GX24Q/4 Pin	2750, 3700	1100-1400	One

NOTES:

- 1) Maximum non-emergency lumen output can vary based on lamp manufacturer, ambient operating temperature, and ballast manufacturer.
- 2) Maximum emergency lumen output is based on total output of one or two lamps, and can vary based on lamp manufacturer and ambient operating temperature.
- 3) Maximum emergency lumen output is supported for a full 90 minutes of operation.
- 4) Consult factory for compatibility, operation and performance of lamp types not listed.

SUGGESTED SPECIFICATION

Furnish and install Chloride's fluorescent emergency ballast model CF1400-4PT. The unit shall be constructed to meet Underwriter's Laboratories, Inc. Standard #924 and the National Electrical Code (NEC).

INSTALLATION AND OPERATION - Unit shall be easily field connected to a 120 or 277 VAC, 60 hertz, unswitched power source. Installation must comply with the NEC as well as other applicable codes. Upon utility power failure or brownout, the unit shall automatically transfer to battery power and maintain the required illumination for a minimum period of 90 minutes. Upon restoration of utility power, the charger shall restore the battery to full charge within UL 924 requirements following a rated discharge of not more than 90 minutes.

CHARGER - Unit shall utilize a solid-state, constant current charging system which will maintain the battery at full capacity without the need for periodic exercising or equalization. The following features shall be standard: low voltage disconnect (LVD), brownout protection and AC lockout.

BATTERY - The battery shall be a maintenance free, nickel cadmium battery. The nickel cadmium battery shall utilize sintered plate construction and polypropylene separators for trouble-free operation in ambient temperatures up to 131°F (55°C). Nickel cadmium batteries shall be supplied with a two year full warranty. The batteries shall be tested and compliant with IEC 61951-1 Life Testing.

ENCLOSURE - The housing shall be constructed of 20 gauge steel with a high temperature powder coat paint finish. The slim housing shall allow for housing frame mounting on most recessed luminaires.