

GENERAL DESCRIPTION

The CLB Series provides low profile, recessed emergency lighting and is also available as a master unit for remote operation.

ILLUMINATION

Illumination is provided by up to four adjustable lamp heads. Choose from round or rectangular thermoplastic heads with Par 36 sealed beam tungsten or halogen, or wedge base tungsten or halogen lamps. Lamp heads are factory installed. The suggested head is Chloride's "W" series wedge base tungsten round lamp head.

DIMENSIONS

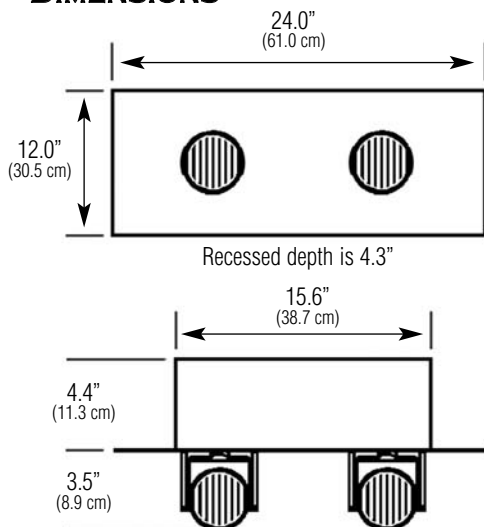

Dimensions are approximate and subject to change.

CLB Series

Recessed Emergency Lighting

6 and 12 Volt, 14 to 50 Watts

Sealed Lead Calcium or Nickel Cadmium Battery

HOUSING

Faceplate constructed of 18 gauge steel with a white epoxy powder coat finish; backbox 20 gauge steel.

Up to four lamp heads can be mounted on units.

Lamp head choices include round or rectangular white thermoplastic to match housing.

Designed for easy, drop-in installation into suspended ceilings.

ELECTRONICS

120/277 VAC dual voltage input with surge-protected, solid-state charging circuitry provides for a reliable charging system.

Charging system is complete with low voltage disconnect, AC lockout, brownout protection, AC indicator lamp and test switch.

Optional ACCU-TEST Self Diagnostics includes an automatic 3 minute discharge test every 30 days. A manual test is available from 1 to 90 minutes.

BATTERY

Maintenance free, sealed lead calcium battery has an estimated service life of 5 years, and an operating temperature range of 65°F (19°C) to 85°F (30°C)

Maintenance free, sealed nickel cadmium battery has an estimated service life of 10 years, and an operating temperature range of 20°F (-7°C) to 95°F (35°C)

Batteries supply 90 minutes of emergency power



SHOWN: CLB6L50WTB2

CODE COMPLIANCE

UL 924 listed

NFPA 101, NEC, BOCA, OSHA and IBC illumination standards

Chicago Approved City Plan No. 1879E

ELECTRICAL SPECIFICATIONS

Input power requirements

120 VAC - 0.150 amps, 18 watts max.

277 VAC - 0.065 amps, 18 watts max.

WARRANTY

Three year full electronics warranty

One year full plus four year prorated lead calcium battery warranty

Five year full plus five year prorated nickel cadmium battery warranty

ORDERING INFORMATION (EXAMPLE: CLB6L50WTB2)



SERIES/BATTERY

Lead Calcium

CLB6L25 = 6 Volt, 25 Watt Unit

CLB6L50 = 6 Volt, 50 Watt Unit

CLB12L50 = 12 Volt, 50 Watt Unit

Nickel Cadmium

CLB6N14 = 6 Volt, 14 Watt Unit

CLB6N28 = 6 Volt, 25 Watt Unit

CLB12N25 = 12 Volt, 25 Watt Unit

CLB12N50 = 12 Volt, 50 Watt Unit



LAMP HEAD

Round Wedge Base

WTA = 6 Volt, 5.4 Watt Tungsten

WTD = 6 Volt, 7.2 Watt, Tungsten

WTB = 6 Volt, 9 Watt Tungsten

WTS = 6 Volt, 7 Watt Halogen

WTN = 6 Volt, 9 Watt Halogen

WTT = 6 Volt, 12 Watt Halogen

WTC = 12 Volt, 9 Watt Tungsten

WTE = 12 Volt, 12.5 Watt Tungsten

WTF = 12 Volt, 17.9 Watt Tungsten

WTV = 12 Volt, 12 Watt Halogen



NO. OF HEADS

4 = Four

3 = Three

2 = Two

1 = One

0 = No Heads



OPTIONS¹

A = Ammeter²

ACF1 = 120 VAC Fuse

ACF2 = 277 VAC Fuse

AD = ACCU-TEST Self-Diagnostics

ADAL = ACCU-TEST with Alarm

ADTD = ACCU-TEST with Time Delay³

TD1 = 120 VAC Time Delay³

TD2 = 277 VAC Time Delay³

V = Voltmeter²

(Suggested lamp heads are listed above.

For other heads, refer to the Accessories Section)

NOTES:

1) Some option combinations may impact UL listing. Consult factory for specifics.

2) Not available with AD, ADAL, or ADTD options.

3) 15 minute delay.

Specification Data for CLB Recessed Emergency Lighting Unit

HOUSING

Recessed box and faceplate are constructed of 18 gauge steel with a white epoxy powder coat finish.

Available lamps heads are either round or rectangular white thermoplastic. Up to four lamp heads can be mounted on unit.

Recessed box is designed for easy, drop-in installation into suspended ceilings.

ELECTRONICS

120/277 VAC dual voltage input with surge-protected, solid-state charging circuitry provides for a reliable charging system. The charging system is furnished with low voltage disconnect, AC lockout, brownout protection, AC indicator lamp and test switch.

The low voltage disconnect (LVD) feature will disconnect the battery prior to an unacceptable deep discharge, but not before the required 90 minute emergency operation.

The AC lockout feature prevents battery drain prior to the initial energizing of utility power, and allows the installer to complete all wiring and electrical connections without energizing the emergency circuit.

The brownout protection circuitry will automatically switch the unit into the emergency mode if the utility voltage sags below 20% of nominal.

Battery charging circuitry is entirely solid-state, and utilizes a constant current charger for nickel cadmium battery units. A fully automatic, voltage regulated charger is used for lead calcium battery units. Battery recharge time after full discharge is less than the required UL 924 standard.

Line sensitive electronics cause an instantaneous transfer to battery power if utility power is lost, or a brownout condition is detected. When line voltage is present and stabilized, the transfer circuitry switches back to normal operation and begins recharging the battery. The transfer circuitry can be tested via a momentary test switch located on the housing.

SELF-DIAGNOSTICS

The ACCU-TEST Self-Diagnostics option conducts automatic and manual tests, and indicates real time status of the lamp, battery and charger via LED indicator lamps. Automatic tests include: Systems analysis every 10 seconds, with actual load tests performed for a 3 minute duration every 30 days. A manual test is available from 1 to 90 minutes..

BATTERY

Maintenance free, sealed nickel cadmium or lead calcium batteries are available. All batteries are equipped with a quick connect plug assembly for easy installation.

Standard sustained emergency operation is for 90 minutes with the illumination source providing full light output.

The suggested operating temperature range for nickel cadmium batteries is 20°F (-7°C) to 95°F (35°C), and the battery has an expected service life of 10 years. The suggested operating range for sealed lead calcium batteries is 65°F (19°C) to 85°F (30°C), and the battery has an expected service life of 5 years.

ELECTRICAL SPECIFICATIONS

Input power requirements

120 VAC - 0.150 amps, 18 watts max.
277 VAC - 0.065 amps, 18 watts max.

CODE COMPLIANCE

The CLB Series meets or exceeds all performance standards as required by UL 924, NFPA 101, NEC, BOCA, OSHA and IBC.

OPERATION

DC Voltage	Unit	Suggested Lamp Head	Watts to 87% of Rated Voltage*			
			1 1/2 hrs.	2 hrs.	4 hrs.	8 hrs.
6	CLB6L25	WTA	25	19	9.5	—
	CLB6L50	WTB	50	37.5	19	10
	CLB6N14	WTA	14	10.5	—	—
	CLB6N28	WTA	25	19	9.5	—
12	CLB12L50	WTC	50	37.5	19	10
	CLB12N25	WTC	25	19	9.5	—
	CLB12N50	WTB	50	37.5	19	10

* Per NEC Specifications

SUGGESTED SPECIFICATION

Furnish and install Chloride's recessed emergency lighting model _____. The unit shall be constructed to meet Underwriter's Laboratories, Inc. Standard #924 and the National Electrical Code (NEC).

INSTALLATION AND OPERATION - Unit shall be easily field connected to a 120 or 277 VAC, 60 hertz, unswitched power source. Installation must comply with the NEC as well as other applicable codes. Upon utility power failure or brownout, the unit shall automatically transfer to battery power and maintain the required illumination for a minimum period of 90 minutes. Upon restoration of utility power, the charger shall restore the battery to full charge within UL 924 requirements following a rated discharge of not more than 90 minutes.

CHARGER - Product shall utilize either a constant current (nickel cadmium) or fully automatic, voltage regulated (lead calcium) charging system. The charging system shall maintain the battery at full capacity without the need for periodic exercising or equalization. The following features shall be standard: Low voltage disconnect (LVD), brownout protection and AC lockout.

BATTERY - The battery shall be either a maintenance free, sealed nickel cadmium or lead calcium battery. The nickel cadmium battery shall utilize sintered plate construction and polypropylene separators for trouble-free operation in ambient temperatures up to 95°F (35°C). The lead calcium battery shall provide trouble-free operation in temperatures up to 85°F (30°C). Nickel cadmium batteries shall be supplied with a five year full warranty, and sealed lead calcium batteries shall be supplied with a one year full warranty.

ILLUMINATION - The unit shall incorporate up to four (Par 36 sealed beam tungsten or halogen; wedge base tungsten or halogen) adjustable lamp heads.

HOUSING - The recessed backbox shall be constructed of 20 gauge galvanized steel, and the faceplate constructed of 18 gauge steel with a white epoxy powder coat finish.



CHLORIDE
SYSTEMS

272 West Stag Park Service Road • Burgaw NC 28425
Telephone: (910) 259 1000 • Facsimile: (800) 258 8803
www.chloridesys.com

C1056R15
8/09 IH