

P.O. BOX 11846 TUCSON, AZ 85734
(520) 294-3292 • FAX (520) 741-2837
www.iotaengineering.com

ETS

EMERGENCY
TRANSFER SWITCH
SERIES A

INSTRUCTION MANUAL

IMPORTANT SAFEGUARDS

When using electrical equipment, basic safety precautions should always be followed, including the following:

READ AND FOLLOW ALL SAFETY INSTRUCTIONS

1. **CAUTION** – This fixture provides more than one power supply output source. To reduce the risk of electrical shock, disconnect both normal and emergency sources by turning off the A.C. branch circuit.
2. **CAUTION** – This is a sealed unit. Replace the entire unit when necessary.
3. **DO NOT USE OUTDOORS.** The **ETS** is for use with grounded, UL Listed, indoor fixtures. Not for use in heated air outlets or hazardous locations.
4. The **ETS** requires an unswitched A.C. power source of either 120 or 277 volts. Properly cap the unused A.C. lead.
5. Do not mount near gas or electric heaters.
6. The **ETS** should be mounted in locations and at heights where it will not readily be subjected to tampering by unauthorized personnel.
7. The **ETS** is compatible with all A.C. magnetic and electronic ballasts.
8. The use of accessory equipment not recommended by the manufacturer may cause an unsafe condition.
9. Do not use this equipment for other than intended use.
10. Install in accordance with the National Electrical Code and local regulations.
11. Installation and servicing should be performed by qualified personnel.
12. Lighting fixture manufacturers, electricians, and end-users need to ensure product system compatibility before final installation.

SAVE THESE INSTRUCTIONS



INSTALLATION INSTRUCTIONS

CAUTION: Before installing, make certain the A.C. power is off.

1. MOUNTING THE ETS

Remove the ballast channel cover. Mount the **ETS** in the ballast channel at least 1/2" away from the A.C. ballast(s).

2. WIRING

Refer to the wiring diagrams on the back page for the appropriate wiring of lamp(s) and ballast. Install in accordance with the National Electrical Code and local regulations. For additional wiring diagrams consult Customer Service.

3. INSTALLING THE LED

Recessed Troffer Fixture – Select a convenient location with proper clearance in the ballast cover and drill or punch a 7/8" hole (1/2" knockout). Insert the 7/8" bushing into the hole. Push the plastic tube through the bushing. Disconnect the leads from the **LED** housing and route the leads down the plastic tube. Reconnect the leads to the housing, observing the proper polarity (Yellow lead to red marked or positive (+) red tab). Push the entire assembly back into the tube until the lens collar rests against the plastic tube. The plastic tube should be adjusted so that the **LED** is within 1/4" of the fixture lens. The **LED** must be visible after installation. Refer to *Illustration 1*.

Strip Fixture – Select a convenient location on the side of the fixture so the **LED** can be seen after installation. Allow for proper clearance inside the fixture and drill or punch a 1/2" hole. Disconnect the leads from the **LED** housing. Push the **LED** housing into the 1/2" hole until it is firmly locked in place. Reconnect the leads, observing the proper polarity (Yellow lead to red marked or positive (+) red tab). Refer to *Illustration 2*.

Illustration 1 Recessed Troffer Fixture

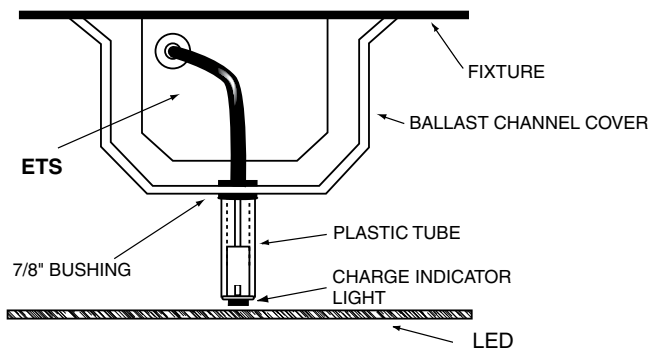
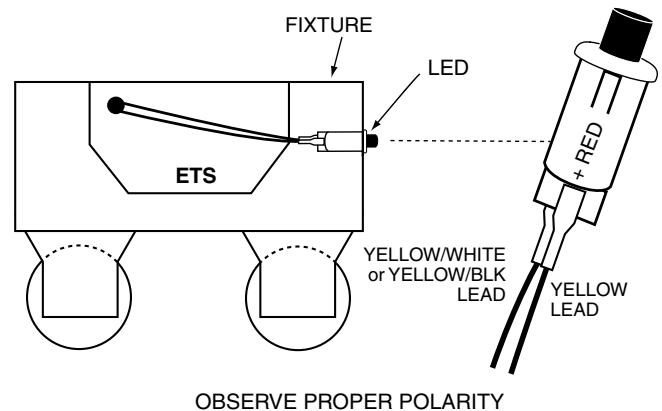

Illustration 2 Strip Fixture



4. WIRING THE A.C. INPUT

Refer to wiring diagrams on Page 4 for the proper wiring configuration of the **ETS**. For wiring diagrams not shown, consult Customer Service.

OPERATION

Normal Mode – A.C. power is present. The A.C. ballast operates the fluorescent lamp(s) as intended.

Emergency Mode – The A.C. power fails. The **ETS** senses the A.C. power failure and automatically switches to the auxiliary generator power. All lamps in the fixture are illuminated at full light output for as long as generator power is available. When the A.C. power is restored, the **ETS** switches the system back to the *Normal Mode*. See page 1 of the Instruction Manual.

TESTING & MAINTENANCE

The **ETS** is a maintenance free unit, however, periodic inspection and testing is required. NFPA 101, Life Safety Code, outlines the following schedule:

Insure that the **LED** light is illuminated monthly.

“Written records of testing shall be kept by the owner for inspection by the authority having jurisdiction.”

SERVICING SHOULD BE PERFORMED BY QUALIFIED PERSONNEL.

Consult Customer Service or visit www.iotaengineering.com for current warranty information.

TYPICAL WIRING DIAGRAMS

For wiring diagrams of ballasts not shown, consult our Customer Service.

1. TYPICAL BALLAST/GENERATOR APPLICATION

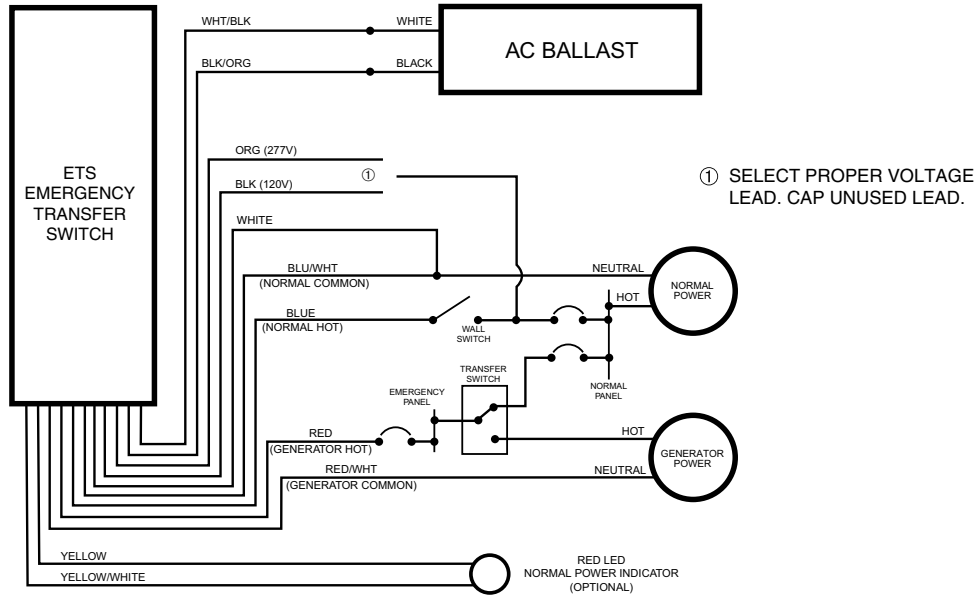

2. TYPICAL DIMMING BALLAST/GENERATOR APPLICATION

