

P.O. BOX 11846 TUCSON, AZ 85734  
(520) 294-3292 • FAX (520) 741-2837  
www.iotaengineering.com

# I-13-EM-J

SERIES D  
COMPACT LAMP  
EMERGENCY  
LIGHTING EQUIPMENT

## INSTRUCTION MANUAL

### IMPORTANT SAFEGUARDS

When using electrical equipment, basic safety precautions should always be followed, including the following:

#### READ AND FOLLOW ALL SAFETY INSTRUCTIONS

1. **CAUTION** – To prevent electrical shock, do not mate unit connector until installation is complete and A.C. power is supplied to the unit.
2. **CAUTION** – This fixture provides more than one power supply output source. To reduce the risk of electrical shock, disconnect both normal and emergency sources by turning off the A.C. branch circuit and by disconnecting the unit connector.
3. **CAUTION** – This is a sealed unit. The integral, high temperature Ni-Cad battery is not replaceable. Replace the entire unit when necessary and recycle or dispose of the nickel-cadmium battery properly.
4. **DO NOT USE OUTDOORS.** The **I-13-EM-J** is for use with grounded, UL Listed, indoor fixtures. Not for use in heated air outlets or hazardous locations.
5. The **I-13-EM-J** requires an unswitched A.C. power source of either 120 or 277 volts. Properly cap the unused A.C. lead.
6. The **I-13-EM-J** and A.C. ballast **must** be on the same branch circuit.
7. Do not mount near gas or electric heaters.
8. The **I-13-EM-J** should be mounted in locations and at heights where it will not readily be subjected to tampering by unauthorized personnel.
9. The **I-13-EM-J** will cold strike and operate *one* 5W, 7W, or 9W, twin tube, double twin tube, 180ma or 13W twin tube, double twin tube, 285ma fluorescent lamp, each with a single lampholder per lamp.
10. The **I-13-EM-J** is for use with fluorescent downlight fixtures.
11. The use of accessory equipment not recommended by the manufacturer may cause an unsafe condition.
12. Do not use this equipment for other than intended use.
13. Install in accordance with the National Electrical Code and local regulations.
14. Installation and servicing should be performed by qualified personnel.

SAVE THESE INSTRUCTIONS



THIS UNIT CONTAINS A  
RECHARGEABLE NICKEL-  
CADMIUM BATTERY. PLEASE  
RECYCLE OR DISPOSE OF  
PROPERLY.

# INSTALLATION INSTRUCTIONS

**CAUTION: Before installing, make certain the A.C. power is off and the I-13-EM-J unit connector is disconnected.**

## 1. MOUNTING THE I-13-EM-J

When used with ceiling mounted downlight fixtures, the **I-13-EM-J** should be mounted on the fixture above the ceiling.

When battery packs are remote mounted, the remote distance can not exceed  $\frac{1}{2}$  of the distance from ballast to lamp specified by the A.C. ballast manufacturer. For example, if the A.C. ballast manufacturer recommends no more than 25' remote distance, then the battery pack should not exceed  $12\frac{1}{2}'$ . Under no circumstances should the battery pack exceed a distance of 50' from the lamp.

## 2. MOUNTING THE TEST SWITCH AND CHARGE INDICATOR LIGHT

Cut a single gang switch box into the ceiling tile adjacent to the fixture within reach of the **I-13-EM-J** flex. After mounting the switch box, connect flex to the box and route all leads inside the box. Connect the leads to the components as follows:

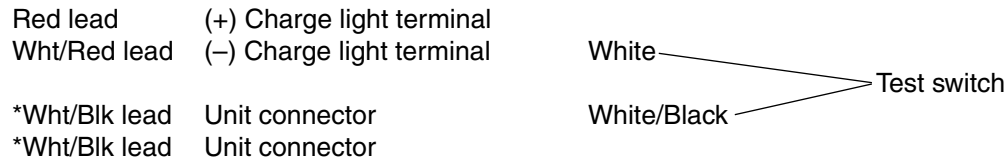

\* To prevent electrical shock and unintentional battery discharge, do not join the unit connector until the installation is complete.

## 3. WIRING

A. The **I-13-EM-J** and A.C. ballast **must** be on the same branch circuit.

B. The **I-13-EM-J** requires an **unswitched** A.C. power source of either 120 or 277 volts; therefore, when used with switched fixtures, the **I-13-EM-J** input must be wired ahead of the switch.

C. Refer to the wiring diagrams on the back page for the proper wiring.

## 4. LABELS

Attach the appropriate labels adjacent to the **Test Switch** and **Charge Indicator**. Annotate Re-lamping label for lamp type and wattage. The Caution and the Re-lamping labels must be on the fixture in a readily visible location to anyone attempting to service the fixture.

## 5. COMPLETING INSTALLATION

When the installation is complete, switch the A.C. power on and join the **I-13-EM-J** unit connector.

**INSURE WIRING IS IN ACCORDANCE WITH THE NATIONAL ELECTRICAL CODE AND LOCAL REGULATIONS.**

# OPERATION

**General** – This unit is primarily designed to be used with compact fluorescent lamp downlight fixtures. It will wire in conjunction with the existing A.C. ballast(s) and lamp(s) to provide the emergency function. It can also be wired for emergency only operation. The **Test Switch** and **Charge Indicator** light are offered for installation in a standard single gang switch box adjacent to the fixture.

**Normal Mode** – A.C. power is present. The A.C. ballast operates the fluorescent lamp(s) as intended. The **I-13-EM-J** is in the standby charging mode. The **Charge Indicator** will be lit providing a visual indication that the battery is being charged.

**Emergency Mode** – The A.C. power fails. The **I-13-EM-J** senses the A.C. power failure and automatically switches to the *Emergency Mode*. One lamp is illuminated, at reduced output, for a minimum of 90 minutes. When the A.C. power is restored, the **I-13-EM-J** switches the system back to the *Normal Mode* and resumes battery charging. See page 1 of the Instruction Manual.

## TESTING & MAINTENANCE

**Initial Testing** – Allow the unit to charge approximately 1 hour, then conduct a short discharge test by depressing the **Test Switch**. The **Charge Indicator** light will go out and the fluorescent tube will be illuminated. When the **I-13-EM-J** is used in fixtures with more than one A.C. ballast, the second A.C. ballast is NOT de-energized with the **Test Switch**. It may, therefore, be advisable to switch the A.C. fixture power off prior to depressing the **Test Switch**. Allow a 24 hour charge before conducting a one hour test.

The **I-13-EM-J** is a maintenance free unit, however, periodic inspection and testing is required. NFPA 101, Life Safety Code, outlines the following schedule:

**Monthly** – Insure that the **Charge Indicator** light is illuminated. Conduct a 30 second discharge test by depressing the **Test Switch**. One lamp should operate at reduced output.

**Annually** – Insure that the **Charge Indicator** light is illuminated. Conduct a full 1½ hour discharge test. The unit should operate as intended for the duration of the test.

“Written records of testing shall be kept by the owner for inspection by the authority having jurisdiction.”

**SERVICING SHOULD BE PERFORMED BY QUALIFIED PERSONNEL.**  
Consult Customer Service or visit [www.iotaengineering.com](http://www.iotaengineering.com) for current warranty information.

# TYPICAL WIRING DIAGRAMS

For use with 2 pin, 5 through 13 watt lamps with integral starter only

## 1. ONE LAMP MAGNETIC BALLAST

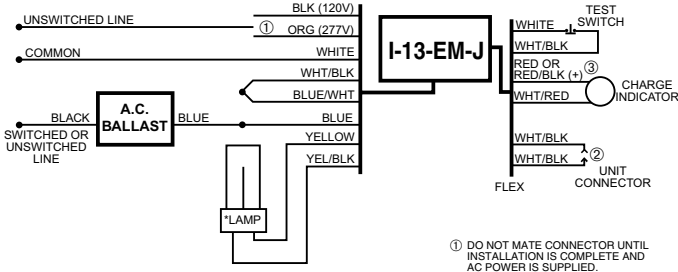

- ① DO NOT MATE CONNECTOR UNTIL INSTALLATION IS COMPLETE AND AC POWER IS SUPPLIED.
- ② LAMP SELECTOR LEADS—REFER TO INSTALLATION INSTRUCTIONS, LAMP OPERATION SECTION FOR VARIOUS OPTIONS.
- ③ TEST ACCESSORY LEADS—REFER TO INSTALLATION INSTRUCTIONS FOR PROPER POLARITY WIRING.

## 2. ONE LAMP HIGH POWER FACTOR MAGNETIC BALLAST

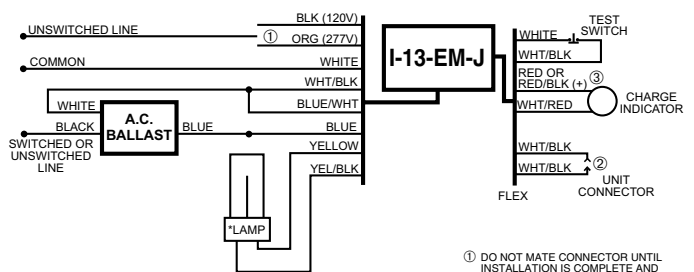

- ① DO NOT MATE CONNECTOR UNTIL INSTALLATION IS COMPLETE AND AC POWER IS SUPPLIED.
- ② LAMP SELECTOR LEADS—REFER TO INSTALLATION INSTRUCTIONS, LAMP OPERATION SECTION FOR VARIOUS OPTIONS.
- ③ TEST ACCESSORY LEADS—REFER TO INSTALLATION INSTRUCTIONS FOR PROPER POLARITY WIRING.

## 3. ONE LAMP ELECTRONIC BALLAST

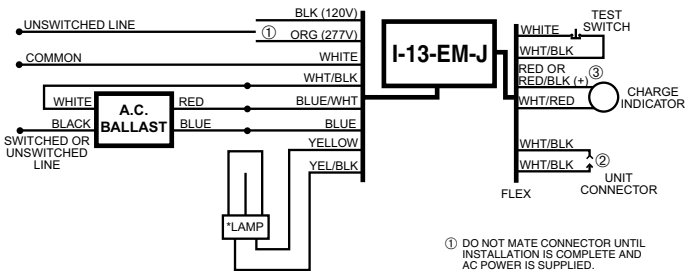

- ① DO NOT MATE CONNECTOR UNTIL INSTALLATION IS COMPLETE AND AC POWER IS SUPPLIED.
- ② LAMP SELECTOR LEADS—REFER TO INSTALLATION INSTRUCTIONS, LAMP OPERATION SECTION FOR VARIOUS OPTIONS.
- ③ TEST ACCESSORY LEADS—REFER TO INSTALLATION INSTRUCTIONS FOR PROPER POLARITY WIRING.

## 4. TWO LAMP ELECTRONIC BALLAST

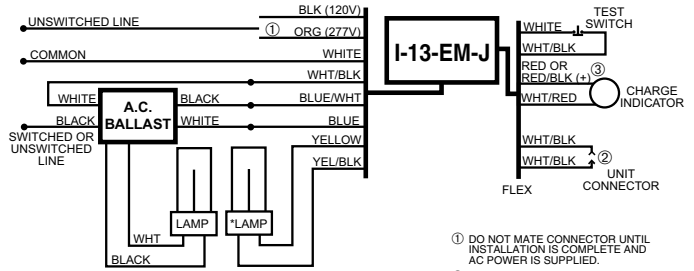

- ① DO NOT MATE CONNECTOR UNTIL INSTALLATION IS COMPLETE AND AC POWER IS SUPPLIED.
- ② LAMP SELECTOR LEADS—REFER TO INSTALLATION INSTRUCTIONS, LAMP OPERATION SECTION FOR VARIOUS OPTIONS.
- ③ TEST ACCESSORY LEADS—REFER TO INSTALLATION INSTRUCTIONS FOR PROPER POLARITY WIRING.

## 5. TWO LAMP PARALLEL MAGNETIC BALLAST

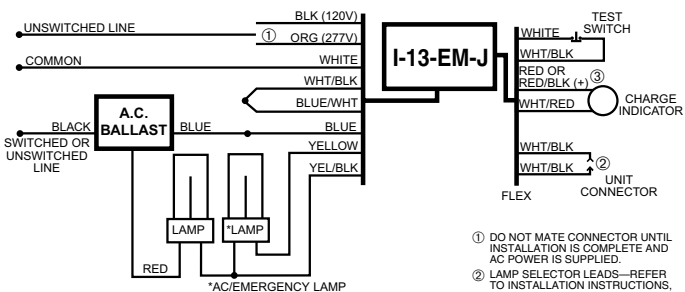

- ① DO NOT MATE CONNECTOR UNTIL INSTALLATION IS COMPLETE AND AC POWER IS SUPPLIED.
- ② LAMP SELECTOR LEADS—REFER TO INSTALLATION INSTRUCTIONS, LAMP OPERATION SECTION FOR VARIOUS OPTIONS.
- ③ TEST ACCESSORY LEADS—REFER TO INSTALLATION INSTRUCTIONS FOR PROPER POLARITY WIRING.

## 6. TWO LAMP PARALLEL HIGH POWER FACTOR MAGNETIC BALLAST

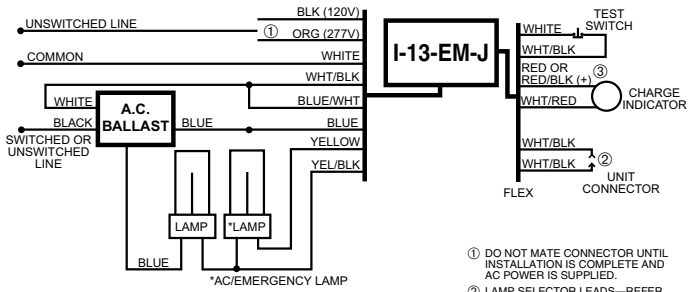

- ① DO NOT MATE CONNECTOR UNTIL INSTALLATION IS COMPLETE AND AC POWER IS SUPPLIED.
- ② LAMP SELECTOR LEADS—REFER TO INSTALLATION INSTRUCTIONS, LAMP OPERATION SECTION FOR VARIOUS OPTIONS.
- ③ TEST ACCESSORY LEADS—REFER TO INSTALLATION INSTRUCTIONS FOR PROPER POLARITY WIRING.

## 7. TWO LAMP SERIES MAGNETIC BALLAST

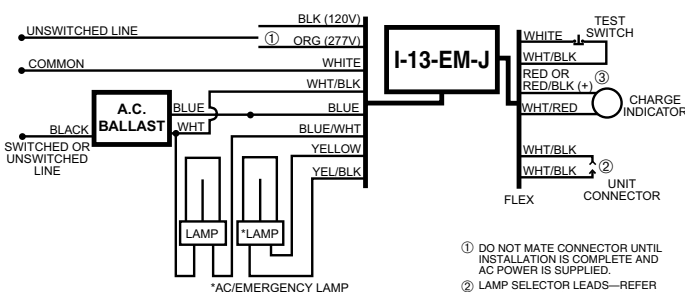

- ① DO NOT MATE CONNECTOR UNTIL INSTALLATION IS COMPLETE AND AC POWER IS SUPPLIED.
- ② LAMP SELECTOR LEADS—REFER TO INSTALLATION INSTRUCTIONS, LAMP OPERATION SECTION FOR VARIOUS OPTIONS.
- ③ TEST ACCESSORY LEADS—REFER TO INSTALLATION INSTRUCTIONS FOR PROPER POLARITY WIRING.

## 8. TWO LAMP SERIES HIGH POWER FACTOR MAGNETIC BALLAST

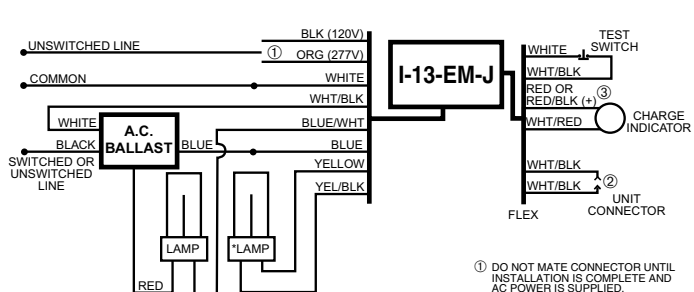

- ① DO NOT MATE CONNECTOR UNTIL INSTALLATION IS COMPLETE AND AC POWER IS SUPPLIED.
- ② LAMP SELECTOR LEADS—REFER TO INSTALLATION INSTRUCTIONS, LAMP OPERATION SECTION FOR VARIOUS OPTIONS.
- ③ TEST ACCESSORY LEADS—REFER TO INSTALLATION INSTRUCTIONS FOR PROPER POLARITY WIRING.

# TYPICAL WIRING DIAGRAMS

For use with 2 pin, 5 through 13 watt lamps with integral starter only.

## 9. TWO NORMAL POWER FACTOR MAGNETIC BALLASTS

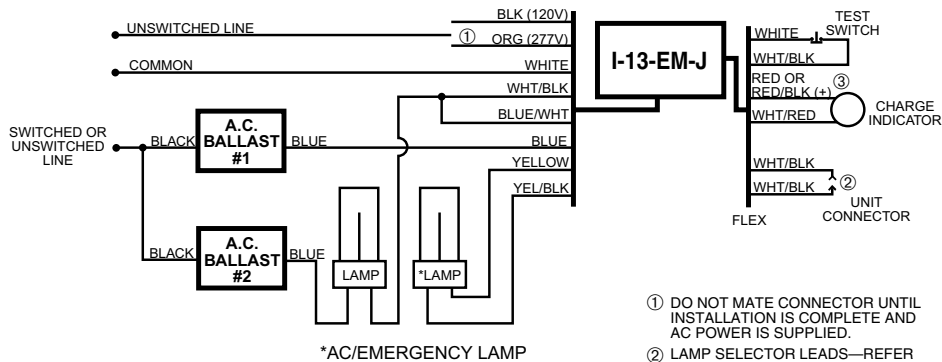

- ① DO NOT MATE CONNECTOR UNTIL INSTALLATION IS COMPLETE AND AC POWER IS SUPPLIED.
- ② LAMP SELECTOR LEADS—REFER TO INSTALLATION INSTRUCTIONS, LAMP OPERATION SECTION FOR VARIOUS OPTIONS.
- ③ TEST ACCESSORY LEADS—REFER TO INSTALLATION INSTRUCTIONS FOR PROPER POLARITY WIRING.

## 10. TWO HIGH POWER FACTOR MAGNETIC BALLASTS

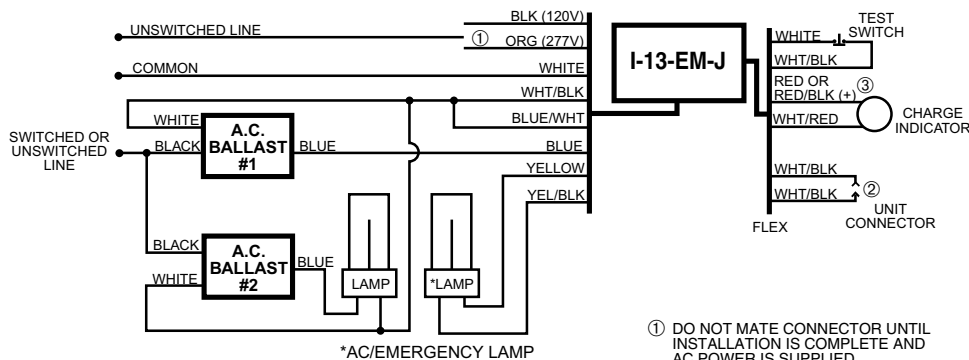

- ① DO NOT MATE CONNECTOR UNTIL INSTALLATION IS COMPLETE AND AC POWER IS SUPPLIED.
- ② LAMP SELECTOR LEADS—REFER TO INSTALLATION INSTRUCTIONS, LAMP OPERATION SECTION FOR VARIOUS OPTIONS.
- ③ TEST ACCESSORY LEADS—REFER TO INSTALLATION INSTRUCTIONS FOR PROPER POLARITY WIRING.