

Type No. _____
 Job Name _____
 Catalog No. _____



Shown: LC-310

LC-310

Sealed Lead Calcium Battery

- **Design Life of 10+ Years**
- **Requires No Regular Exercising**
- **Maintenance Free**
- **Designed Specifically for Low Rate, Long Duration Emergency Lighting Applications**

Battery Construction

- Sealed lead calcium battery
- Never needs water addition, thus reducing maintenance time and costs
- Valve-regulated lead acid with calcium grid alloy
- Immobilized electrolyte design
- Non-gassing
- Operates at low internal pressure
- Tolerant of low temperatures
- Low self-discharge rate
- Recognized component of UL
- Container and cover constructed of high impact ABS plastic

Warranty

3 years full, 7 years pro-rata

Storage/Self discharge characteristics to 50% capacity

TEMP (°F)	TIME (Days)
100	120
80	180
60	300
40	365

Discharge Wattage Capability to 5.25 VDC

30 Min.	1 Hr.	90 Min.	2 Hr.	4 Hr.	8 Hr.
170	125	85	65	28	14

Charging Systems

Designed for Use with LC-310

- Continuously monitors the battery condition and adjusts the charge rate within specifications
- Pulse charge restricts the amount of heat of charge to the battery which is the principal cause of premature battery failure
- Temperature compensation feature adjusts the charge voltage as the ambient temperature changes to prevent overcharging or undercharging of the battery
- Charger restores the LC-310 battery to full charge within 12 hours after discharge

Dimensions

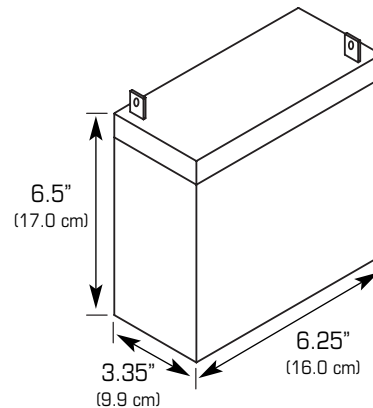

Weight

13.8 lbs.
(6.0 kg)

Dimensions are approximate and subject to change.

LC-310 Sealed Lead Calcium Battery



272 Stag Park Service Road • Burgaw, NC 28425
(910) 259-1131 • FAX (800) 403-6927
www.lightguard.com

L2120R5
5/09 IH