

Type No. \_\_\_\_\_  
 Job Name \_\_\_\_\_  
 Catalog No. \_\_\_\_\_



Shown: U36LT9W



# Unison Series

- Contemporary Emergency Lighting
- 6 Volt, 36 to 72 Watt Units
- Sealed Lead Calcium or Nickel Cadmium Battery

## Housing

- Contractor-friendly, snap-together backplate and housing
- Provisions are available for utility supply via 1/2" surface conduit
- UL 94 V-0, 5 VA high impact thermoplastic
- Available in black or white
- Matching knockouts on thermoplastic backplate enables easy installation to standard junction boxes
- Modular plug-in wiring harness allows line voltage connections in either the junction box or product housing

## Battery

- Batteries are installed and connected to the charger system at the factory
- Maintenance free, sealed lead calcium battery has an expected service life of 5 years with an operating range of 65°F (19°C) to 85°F (30°C)\*
- Maintenance free, sealed nickel cadmium battery has an expected service life of 10 years with an operating range of 20°F (-7°C) to 95°F (35°C)\*

\* Increases or decreases in temperature will affect battery performance and/or capacity. Optimum battery performance realized at 77°F (25°C).

## Illumination

- Illumination is provided by two high performance lamp reflector systems integral to the housing, and enclosed by a high input polycarbonate diffuser
- Each lamp reflector system can be adjusted 180° vertically and 90° horizontally
- The standard lamp reflector system uses a high intensity 9.0 watt T-5 wedge base tungsten lamp

## Operation

DC Voltage	Unit	Watts to 87½ of Rated Voltage*			
		1½ hrs.	2 hrs.	4 hrs.	8 hrs.
6	U36LT9	36.0	27.0	14.0	7.2
6	U50LT9	50.0	37.5	19.0	10.0
6	U72LT9	72.0	56.5	28.5	15.0
6	U50NT9	50.0	37.5	19.0	10.0

\* Per NEC Specifications

## Electronics

- 120/277 VAC dual voltage input with surge protection
- Lead calcium units utilize a solid-state, fully automatic, voltage regulated charger
- Nickel cadmium units utilize a solid-state, constant current charger
- Brownout protection activates lights when AC voltage drops 20% below nominal
- Labor saving AC lockout feature
- Low voltage disconnect switch (LVD) prevents deep battery discharge
- 6VDC remote fixture wiring harness with modular connectors

## Electrical Specifications

36 to 50W	120 VAC: .10 amps, 12 watts
	277 VAC: .04 amps, 11 watts
72W	120 VAC: .39 amps, 46.8 watts
	277 VAC: .17 amps, 47.9 watts

## Self-Diagnostics (optional)

- OmniTest Self-Diagnostics includes automatic and manual tests to ensure unit is operating properly, and assists user in meeting code requirements
- Verifies battery voltage and lamp continuity every 10 seconds
- Illuminates lamps and discharges battery for 3 minutes every 30 days. A manual test is available from 1 to 90 minutes.

## Code Compliance

- UL 924 listed
- UL damp location listing optional
- NFPA 101, NEC, BOCA, OSHA, and IBC illumination standards
- Meets ADA specifications for wall mounted lighting fixtures

## Application

- Ideal for commercial, retail, or office locations where an attractive, highly reliable and easily installed emergency lighting product is needed.

## Warranty

Electronics: 3 years  
 Battery: 1 year full, 4 years pro-rata (lead calcium)  
 5 years full, 5 years pro-rata (nickel cadmium)

# Unison Series 6 Volt Emergency Lighting

## Ordering Information

U				
SERIES/ VOLTAGE	BATTERY/ WATTAGE	LAMP TYPE <sup>1</sup>	HOUSING COLOR	FACTORY INSTALLED OPTIONS <sup>2</sup>
<b>U</b> = 6 Volt, Unison Series Thermoplastic Emergency Lighting Unit	<b>Lead Calcium</b> <b>36L</b> = 36 Watt Unit <b>50L</b> = 50 Watt Unit <b>72L</b> = 72 Watt Unit <b>Nickel Cadmium</b> <b>50N</b> = 50 Watt Unit	<b>T9</b> = Tungsten 9W <b>H7</b> = Halogen 7W <b>H10</b> = Halogen 10W <b>H12</b> = Halogen 12W	<b>W</b> = White <b>B</b> = Black	<b>ACF1</b> = 120 VAC Fuse <b>ACF2</b> = 277 VAC Fuse <b>ACP1</b> = 120 VAC Power Switch <b>ACP2</b> = 277 VAC Power Switch <b>DCP</b> = DC Power Switch <b>DL</b> = UL Damp Location Listing <sup>4</sup> <b>EX</b> = Special Input Transformer (220/240 VAC, 50 Hz) <b>OT</b> = OmniTest Self-Diagnostics <b>OTTD</b> = OmniTest with Time Delay <sup>3</sup>

**NOTES:** 1) Selected lamp wattage cannot exceed unit output rating. 2) Some option combinations may impact UL listing. Consult factory for specifics. 3) 15 minute delay. 4) Available on 50 watt nickel cadmium unit only.

<b>ACCESSORIES</b> (Ordered Separately)
<b>PVS</b> = Polycarbonate Vandal Shield

## Ordering Example

U      50L      T9      W      V  
 Series \_\_\_\_\_  
 Battery/Wattage \_\_\_\_\_  
 Lamp Type \_\_\_\_\_  
 Housing Color \_\_\_\_\_  
 Factory Installed Options \_\_\_\_\_

## Dimensions

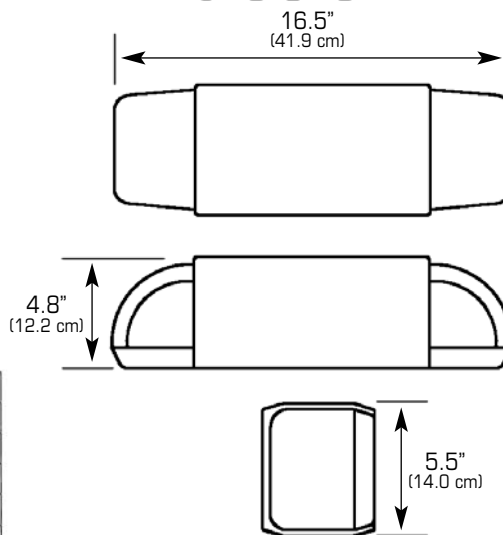

Dimensions are approximate and subject to change.

## Lamp Head Photometrics

T9 Lamp

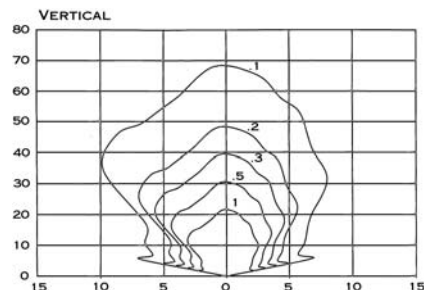
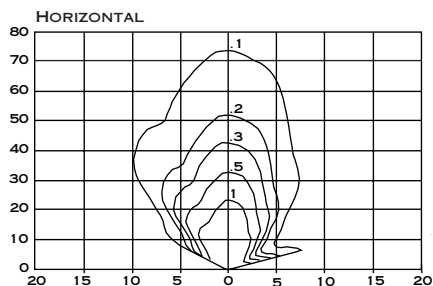

## Suggested Specification

Furnish and install LightGuard decorative emergency lighting model \_\_\_\_\_. The unit shall be constructed to meet Underwriter's Laboratories, Inc. Standard #924 and must be installed to conform to Article 700 of the National Electrical Code (NEC).

**INSTALLATION AND OPERATION** - Unit shall be easily field connected to a 120 or 277 VAC, 60 hertz, unswitched power source. Installation must comply with the NEC as well as other applicable codes. Upon utility power failure or brownout, the unit shall automatically provide emergency battery power and maintain the stated illumination level and output wattage for a minimum period of 90 minutes. Upon restoration of utility power, the charging circuitry shall restore the battery to full charge within UL 924 requirements following a rated discharge of not more than 90 minutes.

**CHARGING CIRCUITRY** - Unit shall utilize either a fully automatic, voltage regulated (lead calcium) or constant current (nickel cadmium) charging system. The charging system shall maintain the battery at full capacity without the need for periodic exercising or equalization. The following features shall be standard: Low voltage disconnect (LVD), brownout protection and AC lockout. Optional self-diagnostics shall monitor and indicate a fault occurring in either the charger, battery, lamp circuit, or input supply.

**BATTERY** - The battery shall be either a maintenance free, sealed lead calcium or sealed nickel cadmium. The sealed lead calcium battery shall provide trouble-free operation in temperatures up to 85°F (30°C) and is supplied with a one year full warranty. Nickel cadmium battery shall provide trouble-free operation in temperatures up to 95°F (35°C) and is supplied with a five year full warranty.

**ILLUMINATION** - Illumination is provided by two internally mounted, fully adjustable reflector systems utilizing either a high output tungsten, or tungsten halogen lamp source. Reflectors shall be constructed of a high efficiency parabolic lamp chamber which can utilize lamp wattages up to 12 watts. When mounted on 20' centers, at 9.0' AFF the product shall provide an average of one footcandle along a linear path of egress.

**HOUSING** - Housing construction shall be impact resistant UL 94 V-0, 5 VA rated thermoplastic. Product shall be furnished with the standard white, or black finish. Units shall be designed to mount to 3 1/2", 4" octagon, or 4" square junction boxes and will be supplied with a knockout pattern to facilitate mounting. Modular utility supply connectors integral to the backplate and housing shall eliminate hardwire line voltage terminations inside of the product housing. The housing and backplate shall snap together without the use of tools, and shall contain a factory installed battery which does not require internal connection prior to energizing the product.

ALL SPECIFICATIONS SUBJECT TO CHANGE WITHOUT NOTICE



272 West Stag Park Service Road • Burgaw, NC 28425  
 (910) 259-1131 • FAX (800) 403-6927  
 www.lightguard.com

L2167R9  
 5/09 IH