

Type No. _____
Job Name _____
Catalog No. _____

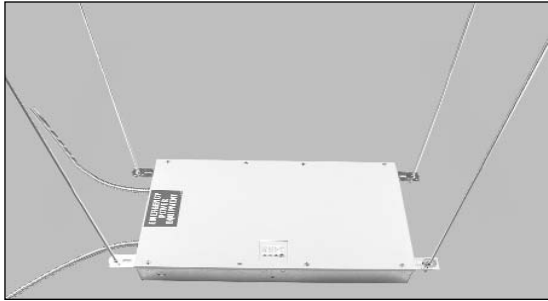

Shown: L960001-CM

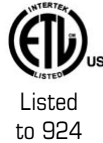

StarPower

150 VA

Interruptible Power Supply for Emergency Lighting Applications

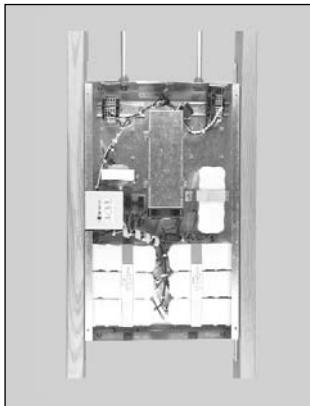

Shown: L960001-RM

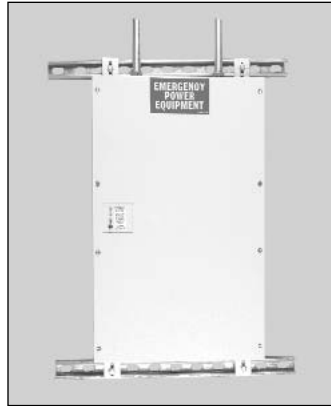

Shown: L960001-SM

Overall Characteristics

- 80% throughput efficiency
- Operating temperature range of 32°F (0°C) to 104°F (40°C); 95°F (35°C) for batteries
- 50 mS maximum transfer time
- Standard 90 minutes of operating time
- Permissible Relative Humidity for Service 0 - 95%

Application

- Operates incandescent and fluorescent electronic ballast loads
- Not recommended for HID lighting loads

Housing

- NEMA 1 enclosure
- Galvanized cabinet with a white powder coat finished door
- Mounting options include: Surface Wall Mount, Ceiling Plenum Mount and Recessed Wall Mount
- Multiple conduit entries

Indicators/Controls

- Local status panel indicators
- Remote status panel (ceiling mount only)
- Optional light switch override capability
- Fused AC output
- Automatic battery monitor with alarm

Warranty

- Electronics: 2 years
- Battery: 5 years full, 5 years pro-rata

Electronics

Inverter

- Square wave output
- Completely solid-state PWM inverter
- Output voltage regulation $\pm 10\%$ of nominal at full load during emergency operation
- Frequency 60.0 ± 1 Hz
- Inverter efficiency $> 70\%$
- Load power factor capability is 0.6 lagging to unity
- Brownout protection is 75% of nominal line voltage
- Low voltage disconnect (LVD)

Charger

- Constant current charge regime
- Recharge time: 24 hours
- Self-contained charger module
- Efficiency: 90% minimum

Battery

- Maintenance free, sealed nickel cadmium battery with an expected life up to 10 years, and optimum operating range of 65°F (19°C) to 85°F (30°C)*

* Increases or decreases in temperature may affect battery performance. Optimum battery performance realized at 77°F (25°C). Batteries are rated at 100% capacity at 77°F (25°C).

System Input/Output

MODEL	UNIT CAPACITY	INPUT (Select One)		OUTPUT		
		AC INPUT VOLTAGES	INPUT AMPS ¹	AVAILABLE OUTPUT VOLTAGES/ MAX. LOAD AMPS		
L96000	150 VA	120	1.60	12 V	120 V	277 V
		277	0.89	12.5 A	1.25 A	
				12.5 A		0.54 A

NOTE: ¹ Maximum input current.

FLUORESCENT LAMP CAPACITY	42w	26w	14w
Quantity (full lumen)	3	5	10

Dimensions/Weights

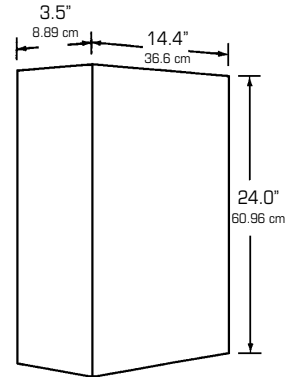

	150 VA
Total Unit w/ Battery	50 lbs. (22.7 kg)

* (1) MICKIT and (1) MIRDIS accessories included
** Drywall Opening Dimensions: 14.5" W x 24.0" L

Ordering Information

SERIES	INPUT/OUTPUT VOLTAGES	MOUNTING CONFIGURATION
L96000 = StarPower Interruptible Power Supply for Emergency Lighting Applications	1 = 120V/120V without Light Switch Option 2 = 120V/120V with Light Switch Option 3 = 277V/277V without Light Switch Option 4 = 277V/277V with Light Switch Option 5 = 120V/12V without Light Switch Option 6 = 120V/12V with Light Switch Option 7 = 277V/12V without Light Switch Option 8 = 277V/12V with Light Switch Option	CM = Ceiling Plenum Installation* SM = Surface Wall Mount RM = Recessed Wall Mount**

Accessories

MIRDIS - Remote Display Assembly for system status monitoring up to 20 ft. away from StarPower.

MICKIT - 20 ft. Cable Kit for connection of Remote Display Assembly.

System One-Line Diagrams

Typical Unit

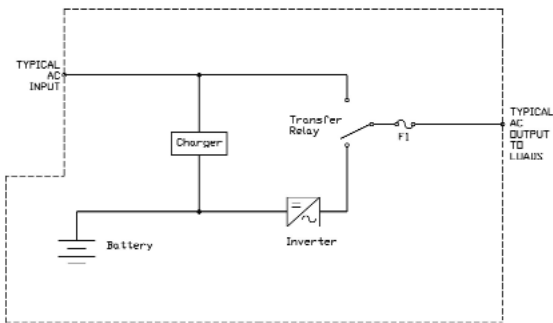

Typical Unit with Light Switch

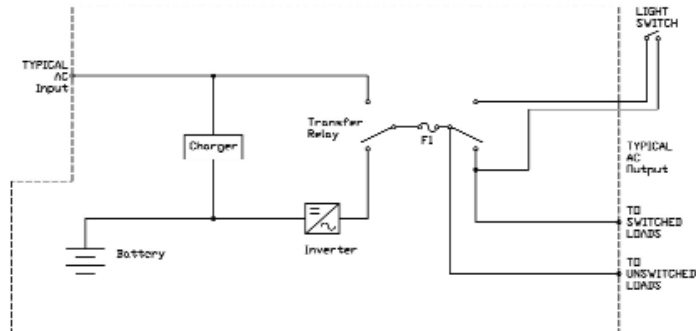

Suggested Specification

Furnish and install LightGuard's Emergency Lighting System known as StarPower with a VA rating of 150. The system shall be square wave output, and shall be ETL listed to Underwriters Laboratories standard 924 and FCC Class A compliant.

Equipment and accessories furnished under the terms of this specification shall be the standard product of a single manufacturer and shall be equal in all respects to those supplied by LightGuard. Catalog numbers and model designations which appear herein indicate design, quality and the type of material as well as required operating characteristics. All equipment shall be in compliance with the applicable UL standards.

The connected load shall be powered normally by utility through the isolating relay and upon failure of the utility input, the load shall automatically continue to be powered via the StarPower's solid-state DC to AC inverter for a period of 90 minutes. Upon restoration of utility power, the inverter will automatically reconnect the load to the utility power.

The StarPower shall be capable of powering any combination of fluorescent ballasted lamps, incandescent lamps or other approved loads up to the total rating of the system. The system shall automatically protect itself against damage from overloads and short circuits while powered from either utility AC or during emergency inverter operation.

Under inverter emergency operations, output voltage shall be within ±10% of nominal at full load for the specified discharge period; and the frequency shall be 60.0 Hz ± 1 Hz.

Continued on Next Page



272 West Stag Park Service Road • Burgaw, NC 28425
(910) 259-1131 • FAX (800) 403-6927
www.lightguard.com



StarPower, 150 VA

Suggested Specification, continued

During inverter emergency operation, the system efficiency shall not be less than 70%. The system shall use mechanical fans in the electronic circuit compartment. The AC output to the load shall be isolated from the utility input during inverter emergency operation. Under emergency mode conditions, the LightGuard StarPower unit is powered by sealed nickel cadmium batteries. The nickel cadmium batteries are encased in a high impact, heat resistant, permanently sealed plastic cover. The batteries will operate entirely unattended and should require no additional maintenance for a period of 10 years. These nickel cadmium batteries are maintained in their fully charged condition whenever the utility power is available. This is done utilizing a solid state, constant current charger that is capable of restoring the batteries to capacity within a maximum of 24 hours

after restoration of utility power. The charger power is obtained from the main power input. The charger has a minimum efficiency rating of 90%. A low voltage disconnect circuit designed to reduce battery discharge during extended power outages, shall monitor the battery voltage and disconnect the inverter when battery voltage drops to approximately 85% of nominal voltage.

System indicators and controls shall consist of local status panel indicators, remote status panel (ceiling mount only), fused AC output, and automatic battery monitor with alarm. System may be configured with the Light Switch Option which causes a switched circuit to be energized in a power failure condition, overriding the manual light switch.

Suggested Applications



Hazardous Locations

Installing the StarPower unit in a safe environment allows you to supply automatically backed up AC power to hazardous location/special requirement fixtures. Designate a specific lighting circuit to provide the required illumination in case of power outage. Install the StarPower unit providing backup power in this circuit and obtain dual utilization of the designated fixtures as both normal and emergency lighting fixtures. The StarPower utilizes nominal line voltage eliminating voltage drop constraints of low voltage DC fixtures and the added expense of special classification fixtures that function only as emergency lighting devices. Some examples are: Painting Facilities, Clean Rooms, Chemical Operations and Waste Water Treatment Plans



Special Requirement Locations

Installing the StarPower unit in a controlled or hidden environment allows you to supply automatically backed up AC power to special requirement fixtures. Designate a specific lighting circuit to provide the required illumination in case of power outage. Install the StarPower unit providing backup power in this circuit and obtain dual utilization of the designated fixtures as both normal and emergency lighting fixtures. The StarPower utilizes nominal line voltage eliminating voltage drop constraints of low voltage DC fixtures allowing remote installation for environmental considerations. Some examples are: Food Processing, Walk-in Cooler/Freezers, Weatherproof/Exterior Egress Routes, Schools and Strip Malls.



Decorative Locations

Installing the StarPower unit in a hidden environment allows you to supply automatically backed up AC power to aesthetically pleasing fixtures. Designate a specific lighting circuit to provide the required illumination in case of power outage. Install the StarPower unit remotely providing backup power in this circuit and obtain dual utilization of the designated fixtures as both normal and emergency lighting fixtures. The StarPower utilizes nominal line voltage eliminating voltage drop constraints of low voltage DC fixtures or the unsightly installation of emergency lighting battery packs. Some examples are: Decorative/Architectural Fixtures in Conference Rooms and Decorative/Architectural Fixtures in Lobbies.

ALL SPECIFICATIONS SUBJECT TO CHANGE WITHOUT NOTICE

