

# CU2HL

HIGH LUMEN LED EMERGENCY LIGHT

tradeSELECT®

## FEATURES

- 2.7W units provide 55' spacing;  
5.4W units have 95' spacing
- Battery recharge within 24 hours
- Damp Location Listed 10°C to 40°C (50°F to 104°F)
- Dual-voltage 120 through 277V AC, 50/60 Hz. input
- Includes long-life Lithium Iron Phosphate battery at 9.6Vdc for UL recognized 90 minute emergency lighting
- Provided with test switch and AC-On indicator
- Self-Test/Self-Diagnostic models available



## SPECIFICATIONS

### DESCRIPTION

- The CU2HL Series is a high lumen output emergency light which includes a long-life Lithium Iron Phosphate battery, and adjustable high-power LED lamp heads
- The emergency light is designed to provide UL924 compliant emergency lighting for the full 90 minutes
- Emergency illumination is provided by 3 high-power LEDs per lamp-head. The CU2HL has a total lumen output of 550 lumens, and the CU2HLHO has a total lumen output of 1300 lumens

### CONSTRUCTION

- The CU2HL is constructed of UL5VA flame-rated and UV-stable corrosion resistant thermoplastic
- Lamp head construction is in polycarbonate
- Housing is available in white or black textured finish

### APPLICATION

- The CU2HL Series is designed for high ceiling height applications, long hallways, large open areas like warehouses, factories, retail stores, schools and other commercial applications
- Designed for wall or ceiling mount to electrical outlet boxes

### COMPLIANCES

- CEC T20 Compliant
- UL924 Listed for Damp Location
- NFPA 101 and NFPA 70
- OSHA

### WARRANTY

- 2 year full unit warranty
- See [HLI Standard Warranty](#) for additional information

## ORDERING GUIDE

Catalog Number	Description
CU2HL	White housing, 2.7W LED lamps, 550 lumens
CU2HLSD	White housing, 2.7W LED lamps, 550 lumens, Self Diagnostics
CU2HLHO	White housing, 5.4W LED lamps, 1300 lumens
CU2HLHOSD	White housing, 5.4W LED lamps, 1300 lumens, Self Diagnostics
CU2HLB	Black housing, 2.7W LED lamps, 550 lumens
CU2HLSDB	Black housing, 2.7W LED lamps, 550 lumens, Self Diagnostics
CU2HLHOB	Black housing, 5.4W LED lamps, 1300 lumens
CU2HLHOSDB	Black housing, 5.4W LED lamps, 1300 lumens, Self Diagnostics

### Accessories (Order Separately)

**WGLZ** wireguard 6.25"H x 14"W x 4" D

Single Carton Weight	2.6 lbs.
Master Carton Quantity	6 each

# CU2HL

HIGH LUMEN LED EMERGENCY LIGHT

## APPLICATION INFORMATION

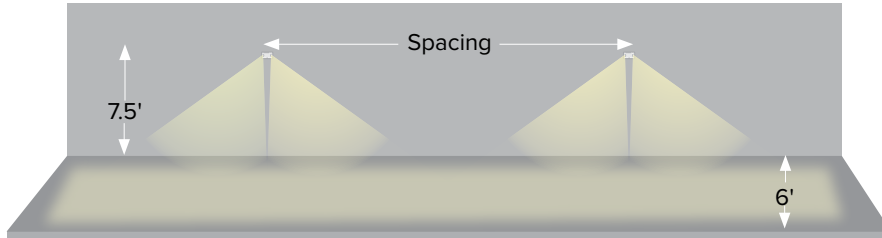

Multiple Unit Spacing  
(7.5' Mounting Height)

	Spacing	Path Width
CU2HL (2.7 Watt lamps)	55'	6'
CU2HL (5.4 Watt lamps)	95'	6'

Meets Life Safety Code minimum illuminance of 0.1fc and average illumination of 1.0 fc. Photometry files available at [www.compasslightingproducts.com](http://www.compasslightingproducts.com)

## SELF-TEST / SELF-DIAGNOSTIC FUNCTIONALITY

- Unit performs a Self-Test for 3 minutes once per month, and a 90 minute annual test
- Unit Monitors Battery Voltage, Charger function, Transfer Circuit and Lamp, and will provide a blinking fault code for each of these conditions

## INPUT POWER CONSUMPTION

	120VAC, 60Hz		277VAC, 60Hz	
	Watts	Amps	Watts	Amps
93130907 CU2HL	0.9W	18mA	1.0W	12mA
93130908 CU2HLSD	1.69W	30mA	1.97W	18mA
93130909 CU2HLHO	2.58W	44mA	2.6W	25mA
93130910 CU2HLHOSD	2.8W	43mA	3.1W	27mA
93130911 CU2HLB	0.9W	18mA	1.0W	12mA
93130912 CU2HLSDB	1.69W	30mA	1.97W	18mA
93130913 CU2HLHOB	2.58W	44mA	2.6W	25mA
93130914 CU2HLHOSDB	2.8W	43mA	3.1W	27mA

## DIMENSIONS

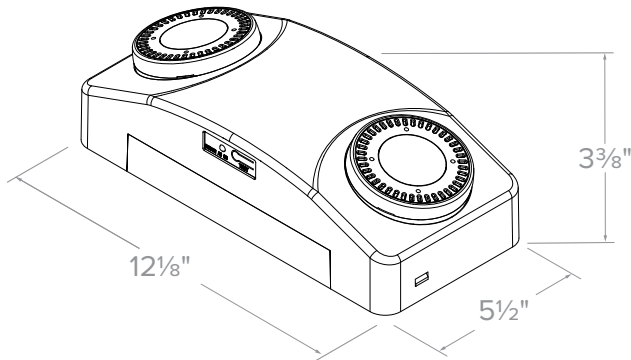

## LAMP ADJUSTABILITY

