

Features

- Injection-molded thermoplastic ABS housing
- UL 94V-0 flame rating
- Innovative, snap-together design allows for fast installation
- Two flush mounted fresnel lenses maximize light output and provides glare free light distribution
- Wall or ceiling mounting
- Easily removed mounting knock-outs and J-box pattern on back panel
- 120/277 VAC dual voltage operation
- Test switch and charge rate indicator
- 2 X 6V 5.4W DC T5 wedge lamps for emergency mode
- Battery delivers more than 90 minutes capacity to emergency lamps
- 24 hours recharge after 90 minutes discharge
- Low voltage battery disconnection preventing deep discharge damage to the battery
- Operating temperature range of 10°C to 40°C
- Two 5.4W 6V lamps providing illumination
- UL Listed for damp location
- Meets NFPA 101, NEC, and NEMA code

Dimensions

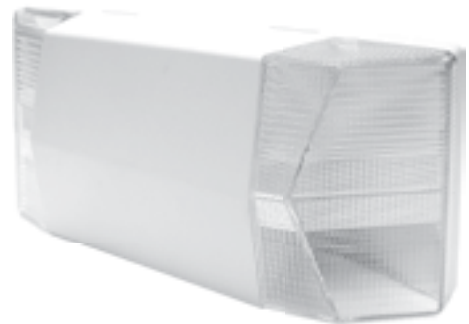
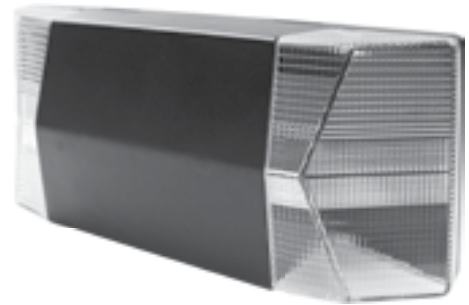
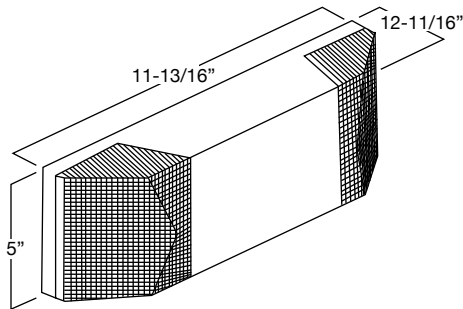

Ordering Information

Item #	Description
21760	Emergency Light 2 x 5W 6V Prismatic Flush Heads White Body
21762	Emergency Light 2 x 5W 6V Prismatic Flush Heads Black Body

Accessories

Item #	Description
207WG	Wire Guard for Exit Sign
207WGWH	White Wire Guard for Exit Sign
207PS	Polycarbonate Shield for Exit Sign
20734J	Replacement Lead Acid Battery 6V 4.5Ah