

The 700U Series EXIT features high-intensity red or green LEDs providing bright and uniform illumination, while offering durability and strength in a 20 gauge steel enclosure. Attractive and easy to install. The 700U Series is ideal for any commercial, institutional, or industrial application.

Model: _____ Date: _____
Accessories: _____
Job Name: _____ Type: _____

FEATURES & BENEFITS

- Enclosure constructed of 20 gauge welded steel
- Universal - includes 2 faceplates, backplate and mounting canopy
- Ceiling, end, or wall mount
- Guardian Self-test/Self-diagnostics (G2) option
- Damp Location Rated (standard)



SPECIFICATIONS

Illumination: Long-life, high-intensity, red or green LEDs.
Housing: Rugged 20 gauge galvanized steel housing
Input: 120/277VAC Dual primary, 60Hz
Battery: Maintenance-free 4.8V NiCad battery
Operating Temp: 0°C to 50°C (32°F to 122°F)
Run Time: 90 minute emergency run time, 24 hour recharge time
Legend: Fully illuminated 6" characters with 3/4" stroke and field-selectable directional chevrons
Mounting: Ceiling, end or wall mounted, canopy included
Finishes: Black or White
Options: G2 = Self-test/Self-diagnostics
Certifications: UL 924 Listed for Damp Locations, Meets NFPA 101 Life Safety Code, NEC, OSHA, California Energy Commission (CEC) Title 20 Compliant
Warranty: Any component that fails due to a manufacturing defect is guaranteed for five years with a separate five year prorated warranty on the battery. The warranty does not cover physical damage, abuse or instances of uncontrollable natural forces. See the full Exitronix warranty document for detailed information. (Terms and Conditions apply)

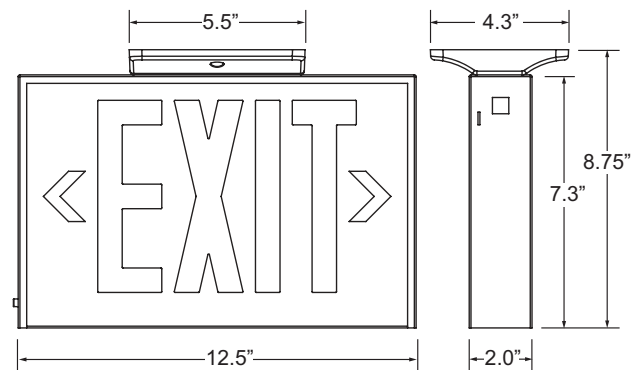

ORDERING INFORMATION Example: 700U-WB-BL-G2

Series	Power Source	Finish	Options (Factory Installed)	Accessories ³ (Field Installed)
700U ¹ = Red Universal	LB = AC Only	WH = White	G2 ² = Self-Test/Self-Diagnostics	WG-S = Wire Guard (Back Mount)
G700U ¹ = Green Universal	WB = NiCad Battery	BL = Black		XG-1 = Poly Guard (Back Mount)
				XG-3 = Poly Guard (Ceiling Mount)
Notes				EXI Warranty = Extended Warranty (10 Yr)

¹ Universal includes 2nd exit face and backplate

² Available only with WB units

³ Order as separate line item

CONSTRUCTION

Our steel 700U exit enclosure and mounting canopy (included) are 20 gauge galvanized steel with baked-on, powder-coated paint. Faceplate is .031 thick steel and has 3/4" letters with red or green LEDs. Stencil letters are 6" high with 3/4" stroke.

ILLUMINATION

Illumination of the 700U Series is accomplished utilizing high-intensity, long-life LEDs exceeding UL 924 requirements for brightness and uniformity. LEDs provide excellent illumination while maximizing energy efficiency. LEDs are a maintenance-free solution, providing up to 100,000 hours of use without failure.

ELECTRICAL

Input

Dual-voltage input 120 or 277VAC @ 60Hz

Nickel Cadmium Battery - NiCad (With Battery Only)

Exitronix nickel cadmium batteries are maintenance-free.

Emergency

The 700U Series exit will operate for a minimum of 90 minutes during a loss of power with a 24 hour maximum recharge time for the battery.

Solid-State Transfer

The circuit features solid-state switching for emergency backup, eliminating concerns of damaged contact or mechanical failures associated with relays. The switching circuit detects a loss of line voltage and automatically switches to emergency mode.

Test Button

The test button is easy to locate and provides manual verification of the transfer circuit.

INSTALLATION

Interchangeable stencil faceplate and/or backplate slide-fit flush into frame for optimum light seal. Fastening is done by means of a Phillips head screw located in the center bottom frame. Backplate is supplied with a universal knockout pattern for quick, easy installation. Canopy included is low profile and offers simple installation for either top or side mount.

OPTIONS

Guardian Self-Test/Self-Diagnostics (Option: G2)

The Guardian bi-color circuit is factory preset; without any field adjustments needed. It continuously monitors the performance condition of the AC power, battery supply and charging circuitry. The intent of this option is to provide visual signaling to identify fault at the exit. Fault indicators are as follows:

Battery Disconnection: (Steady RED)

Battery Recharge Failure: (Flashing RED)

Battery Failure: (RED Blinking '2' times)

LED Failure: (RED Blinking '3' times)

CONFORMANCE TO CODES & STANDARDS

The 700U Series is UL 924 Listed for Damp Locations and meets or exceeds the following: CEC (T20), NEC requirements and NFPA 101.