

B84CG

Installation Instructions

EMERGENCY LIGHTING EQUIPMENT

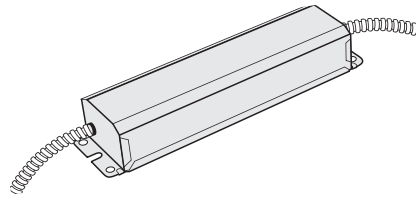

PHILIPS
bodine



! IMPORTANT SAFEGUARDS !

WHEN USING ELECTRICAL EQUIPMENT, BASIC SAFETY PRECAUTIONS SHOULD ALWAYS BE FOLLOWED, INCLUDING THE FOLLOWING:

READ AND FOLLOW ALL SAFETY INSTRUCTIONS

1. To prevent high voltage from being present on red, yellow & yellow/black output leads prior to installation, inverter connector must be open. Do not join inverter connector until installation is complete and AC power is supplied to the emergency ballast.
2. This product is for use with one 13 W through 42 W (4-pin) compact fluorescent lamp without integral starters.
3. Make sure all connections are in accordance with the National Electrical Code and any local regulations.
4. To reduce the risk of electric shock, disconnect both normal and emergency power supplies and inverter connector of the emergency ballast before servicing.
5. This emergency ballast is for factory or field installation on top of or remote from the fixture.
6. This product is suitable for damp locations where the ambient temperature is 0°C minimum, +50°C maximum. Product is not suitable for heated air outlets and wet or hazardous locations.
7. An unswitched AC power source is required (120 or 277 VAC, 60 Hz).
8. Do not install near gas or electric heaters.
9. Do not attempt to service the battery. A sealed, no-maintenance battery is used that is not field replaceable. Contact the manufacturer for information on service.
10. The use of accessory equipment not recommended by the manufacturer may cause an unsafe condition.
11. Do not use this product for other than intended use.
12. Servicing should be performed by qualified service personnel.

CAUTION: Verify that all replacement lamp types marked on the installed luminaire are also identified as suitable for use with this inverter/charger pack.

SAVE THESE INSTRUCTIONS



Ni - Cd

**THIS PRODUCT CONTAINS A RECHARGEABLE NICKEL-CADMIUM BATTERY.
THE BATTERY MUST BE RECYCLED OR DISPOSED OF PROPERLY.**

08/28/15

© Philips Emergency Lighting

INSTALLATION



WARNING: TO PREVENT HIGH VOLTAGE FROM BEING PRESENT ON RED, YELLOW & YELLOW/BLACK OUTPUT LEADS PRIOR TO INSTALLATION, INVERTER CONNECTOR MUST BE OPEN. DO NOT JOIN INVERTER CONNECTOR UNTIL INSTALLATION IS COMPLETE AND AC POWER IS SUPPLIED TO THE EMERGENCY BALLAST.

NOTE: Make sure that the necessary branch circuit wiring is available. An unswitched source of power is required. The emergency ballast must be fed from the same branch circuit as the AC ballast.

STEP #1 ▶ INSTALLING THE EMERGENCY BALLAST

- > Disconnect AC power from the fixture.
- > Refer to illustration below to install the emergency ballast and test/monitor plate. Make electrical connections in accordance with the National Electrical Code and any local regulations. The test/monitor plate may be installed close to the fixture in the ceiling or at a remote location (up to 50 feet). The emergency ballast may be remotely installed up to 1/2 the distance the AC ballast manufacturer recommends removing the AC ballast from the lamp, or up to 6 feet, whichever is less. If no AC ballast is used, the emergency ballast can be remotely mounted up to 6 feet away. Note: A switch box is not supplied.
- > **Mounting Height:** This product meets or exceeds the NFPA minimum light requirements with all loads, down to the smallest rated lamp load, at heights up to 7.17ft (2.2m). Many factors influence emergency illumination levels, such as the lamp load selected, luminaire design, and environmental factors therefore end use verification is necessary. For field installations, when the attached luminaire is mounted at heights greater than 7.17ft (2.2m), the level of illumination must be measured in the end application to ensure the requirements of NFPA 101 and local codes are satisfied.

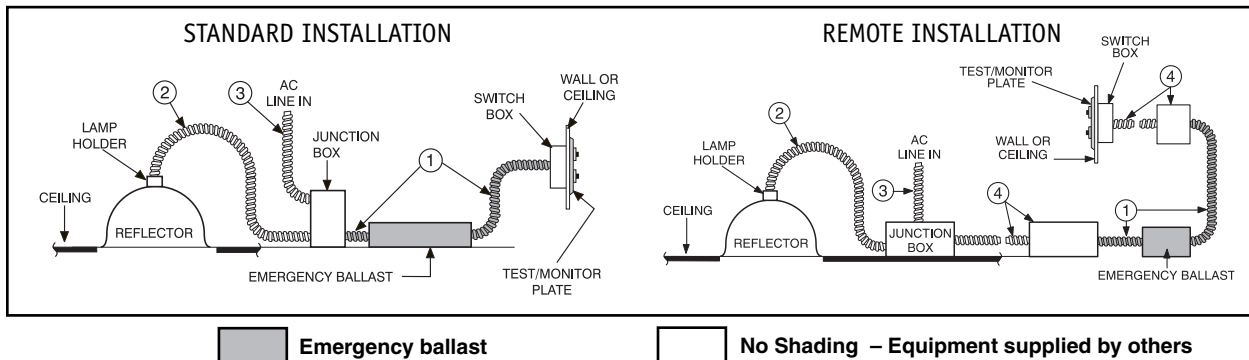

- ① – Flexible conduit (supplied) to connect ballast wires.
- ② – Existing conduit to run existing wires to lamp holder (AC ballast on junction box). If AC ballast is on reflector, run yellow, yellow/black, blue/white, blue and red wires from emergency ballast through this conduit.
- ③ – AC line in.
- ④ – Conduit and junction box (not supplied), necessary for remote installation.

STEP #2 ▶ WIRING THE EMERGENCY BALLAST

- > Select the appropriate wiring diagram to connect the emergency ballast to the AC ballast and lamp.
- > For rapid start AC ballast cut fixture wires between the lamp holder and AC ballasts and connect the blue and blue/white emergency ballast wires to the AC ballast and the yellow and yellow/black wires to the lamp holder.
- > On switched fixtures, an additional unswitched hot (120 or 277 VAC) wire must be run to the junction box and connected to the emergency ballast.
- > The emergency ballast must be connected to an unswitched 120 or 277 VAC power source. Do not connect to other voltages. After fixture installation is complete, supply AC power to the emergency ballast and join the inverter connector.
- > Connect LED by matching violet and brown leads.

INSTALLATION

STEP #3 EMERGENCY BALLAST QUICK CHECK AND LABELING

- > For short-term testing of the emergency function, the battery must be charged for at least one hour. The emergency ballast must be charged for at least 24 hours before conducting a long-term test.
- > In a readily visible location, attach the label "**CAUTION: This Unit Has More Than One Power Supply Connection Point. To Reduce The Risk Of Electric Shock, Disconnect Both The Branch Circuit-Breakers Or Fuses And Emergency Power Supplies Before Servicing.**"

OPERATION

When AC power is applied, the charging indicator light is illuminated, indicating that the battery is being charged. When power fails, the emergency ballast automatically switches to emergency power (internal battery), operating one lamp at reduced illumination. This emergency ballast will operate one 13 W through 42 W lamp for a minimum of 90 minutes. When AC power is restored the normal ballast operation is delayed for approximately three seconds to prevent false tripping of AC ballast (end-of-lamp-life) shutdown circuit.

MAINTENANCE

Although no routine maintenance is required to keep the emergency ballast functional, it should be checked periodically to ensure that it is working. The following schedule is recommended:

1. Visually inspect the charging indicator light monthly. It should be illuminated.
2. Test the emergency operation of the fixture at 30-day intervals for a minimum of 30 seconds. One lamp should operate at reduced illumination.
3. Conduct a 90-minute discharge test once a year. One lamp should operate at reduced illumination for at least 90 minutes.

! REFER ANY SERVICING INDICATED BY THESE CHECKS TO QUALIFIED PERSONNEL !

IMPORTANT: REFER TO TABLE 1 REGARDING THE BROWN CONNECTOR.

Table 1

LAMP POWER	BROWN CONNECTOR
13 -18 W	CLOSED
24 -42 W	OPEN

EMERGENCY BALLAST AND AC BALLAST MUST BE FED FROM THE SAME BRANCH CIRCUIT
 TYPICAL SCHEMATICS ONLY. MAY BE USED WITH OTHER BALLASTS. CONSULT THE FACTORY FOR OTHER WIRING DIAGRAMS.

WIRING DIAGRAMS for 1-LAMP emergency operation

RAPID START AC BALLASTS

FIG A. ONE (1) 4-PIN COMPACT LAMP RAPID START BALLAST

FIG B. TWO (2) LAMP RAPID START BALLAST

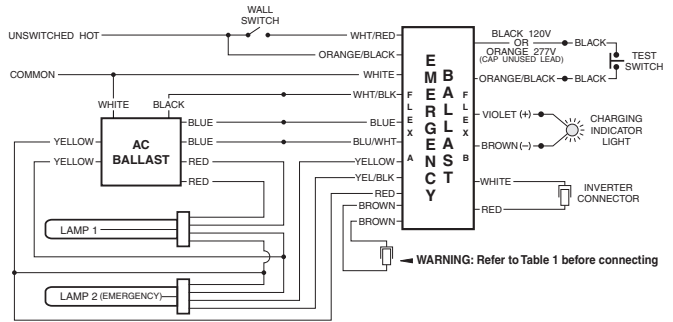
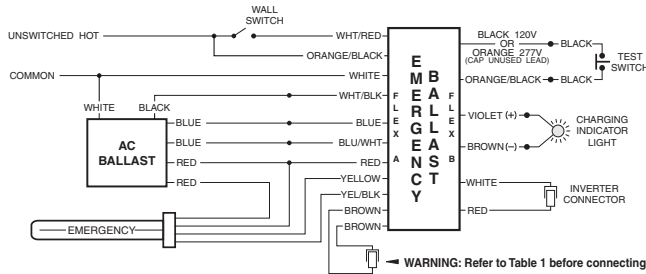

WIRING DIAGRAMS for Emergency-Only fixtures

FIG E. ONE (1) LAMP WITHOUT AC BALLAST

