

Ultra Thin LED Downlight with Emergency Battery Backup

The BBDL is a popular Ultra Thin Profile LED Downlight for versatile installation. Big Beam's unique BBDL comes standard with battery backup, versions without battery backup are available. Battery Backup minimum runtime of 90 minutes. FIELD SELECTABLE COLOR TEMPS OF 3000K- 4000K-5000K. Available in 4", 6", & 8"

FEATURES

- 120-277V
- 4W or 10W Emergency Battery Backup & Test Switch
- Field Selectable Color Temps of 3000K, 4000K and 5000K. Dip Switch on the Battery Backup box
- SMD 2835, CRI 80
- Standard with White Trim
- Junction box included
- Damp rated; suitable for bathroom installations.
- LED fixture, junction box and Battery Backup are detachable.
- Edge lit technology eliminates hot spots, smooth 3" wide spread,
- Dimmable with most wall/box dimmers.
- Approved by ETL Standards for Canada and USA.
- Extruded Aluminum Housing with Polycarbonate lens.
- Stainless steel locking mechanisms.

Field Selectable Color Temps
3000K-4000K-5000K

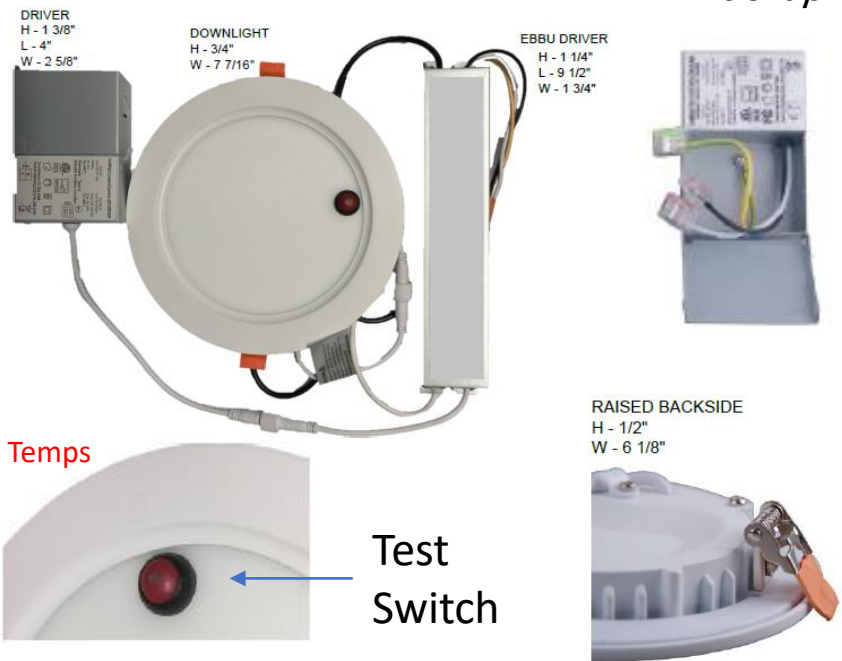

WARRANTY

5 Year Warranty

IC RATED

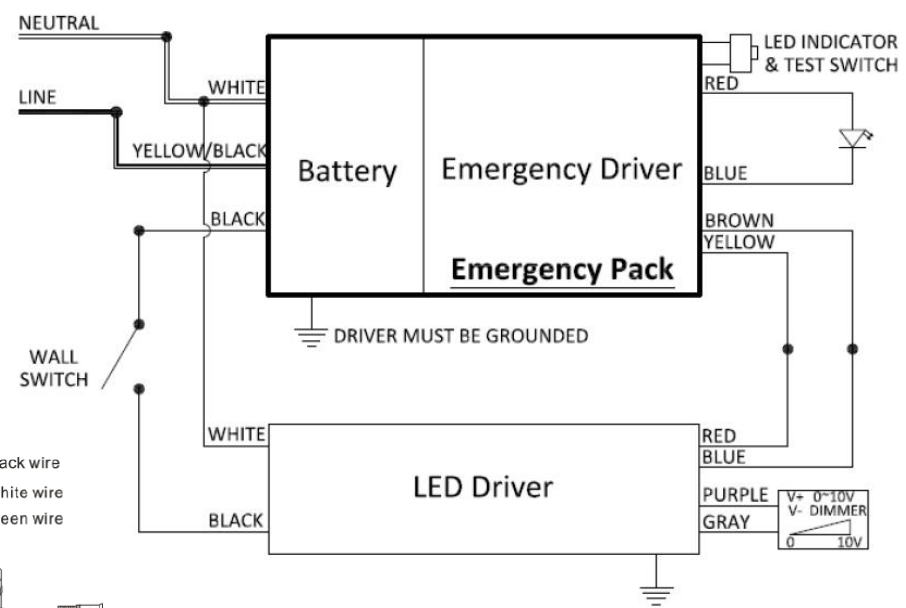
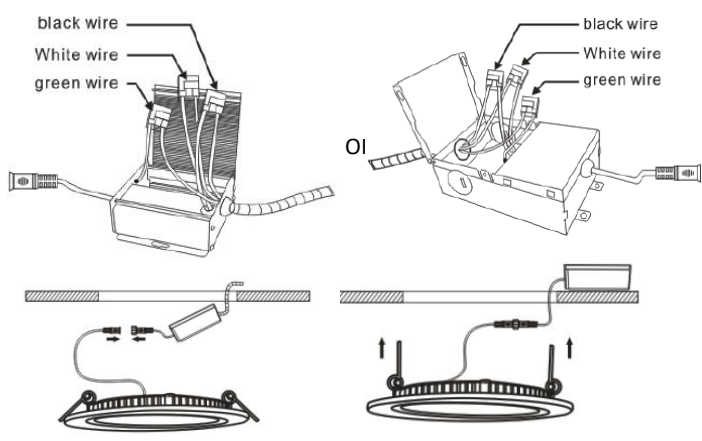

Hole-Cut Size:

4 3/4" ± 1/8"	6 1/2" ± 1/8"	8" ± 1/8"
95 ± 3 mm	165 ± 3 mm	205 ± 3 mm
4"	6"	8"

Series	Size	Battery Backup	Options
BBDL	4 = 4" (9W, 630lms)	4 = 4W	-NBBU = No Battery Backup
	6 = 6" (16W, 1120lms)	10 = 10W	
	8 = 8" (18W, 1260lms)		

