



TYPE: _____
 CATALOG #: _____

 NOTES: _____



CCTS Series

6, 12 and 24 Volt T-Bar Units

Features

- Each unit comes with two (2) 6 or 12V-12W sealed beam halogen EF28 lamp heads (standard). Provisions for mounting three heads are included
- Constructed of 20-gauge steel with an off-white baked enamel finish
- Available with sealed, maintenance-free Nickel-Cadmium or Lead-Calcium batteries
- PulsePlus Charger circuitry offers 120/277V input 60Hz., 0.3/0.15A (other inputs available), fused output circuit(s), dual diagnostic indicator lights, temperature compensated charger, sealed relay, low voltage battery disconnect, brownout protection and lock out (automatic battery connect)
- Fully-recessed housing for unobtrusive use in T-Bar ceilings. A removable cover on the back box allows for ease of installation and full access to the battery and charger
- UL924 Listed
- Meets City of Chicago requirement
- 3-year limited warranty
 Detailed warranty terms located at: www.emergi-lite.com/usa/files/EL_Warranty.pdf

Unit Rating

Furnished standard with two 9 watt High Intensity Incandescent lamps.

UNIT EQUIPMENT - WITH REMOTE CAPABILITY						
Sealed Maintenance-Free Battery Types	D.C. Voltage	Model Number	Watts to 87-1/2% of rated battery voltage*			
			1 ^{1/2} hrs	2 hrs	3 hrs	4 hrs
Nickel-Cadmium	6	CCTSC25-2	25	18	12	9
	12	CC12TSC36-2	36	21	15	12
	12	CC12TSC50-2	50	36	25	18
Lead-Calcium	6	CCTSM27-2	27	18	14	10
	6	CCTSM36-2	36	25	20	14
	6	CCTSM54-2	54	37	28	21
	6	CCTSM110-2	110	72	56	40
	12	CC12TSM36-2	36	25	20	14
	12	CC12TSM54-2	54	37	28	21
	12	CC12TSM110-2	110	72	56	40

* National Electrical Code Specification

Accessories (order as a separate item)

DESCRIPTION	SUFFIX
Remote Test Switch (metal face plate)	RTS
Remote Test Switch (plastic face plate)	RTS-1

Dimensions

Dimensions are approximate and subject to change.

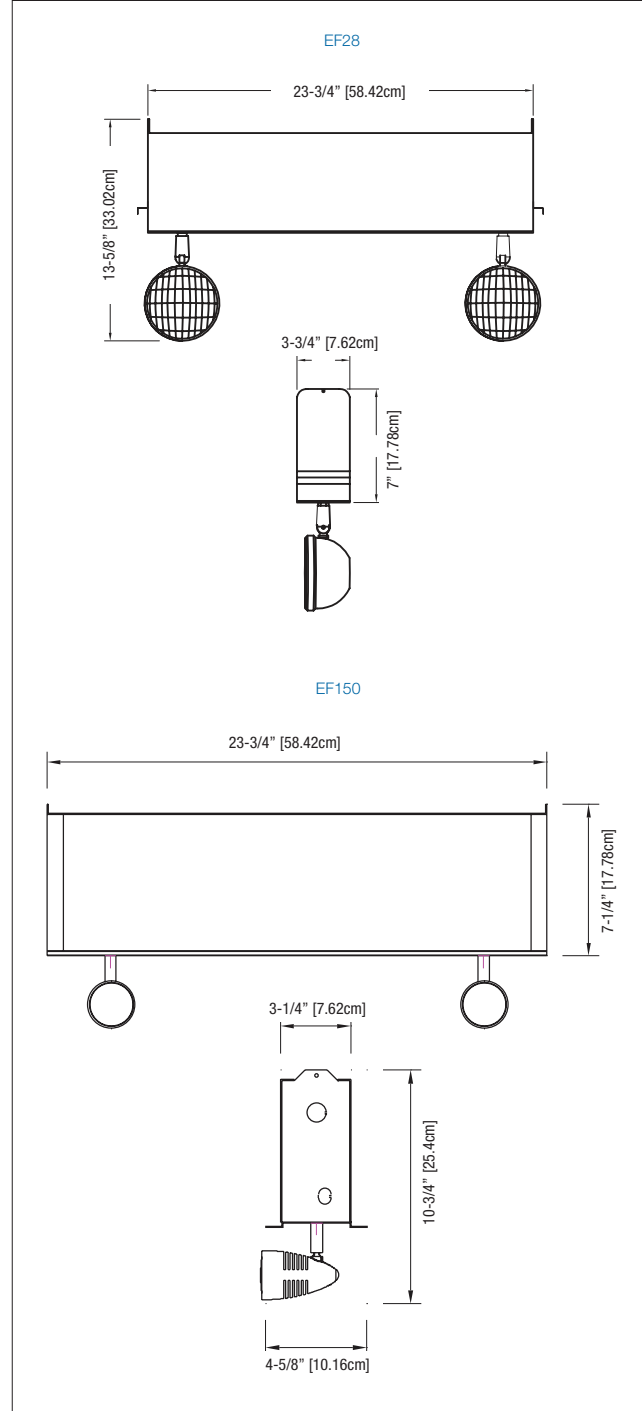

TYPE: _____
 CATALOG #: _____

 NOTES: _____



Designed for unobtrusive use in T-Bar ceilings. The off-white, fully recessed housing harmonizes with ceiling designs

How to Order

SERIES	SERIES/BATTERY TYPE/ CAPACITY	# OF HEADS	HEAD STYLE	LAMP TYPE/WATTAGE	OPTIONS
CC = City of Chicago Approved	TSC25 = 6V-25W Ni-Cd TSM27 = 6V-27W Lead-Calcium TSM36 = 6V-36W Lead-Calcium TSM54 = 6V-54W Lead-Calcium TSM110 = 6V-110W Lead-Calcium 12TSM36 = 12V-36W Lead-Calcium 12TSM54 = 12V-54W Lead-Calcium 12TSM110 = 12V-110W Lead-Calcium 12TSC36 = 12V-36W Ni-Cd 12TSC50 = 12V-50W Ni-Cd	-0 = No head -1 = One head -2 = Two heads -3 = Three heads	Blank = EF28 heads 150 = EF150 Deco heads MR16	Blank = 6V-12W or 12V-12W sealed beam halogen HG = 12V-12W Halogen bi-pin MK = 12V-12W MR16 Halogen LA = 6V-4W, MR16 LED LG = 12V-4W, MR16 LED LJ = 12V-5W, MR16 LED LJ = 12V-6W, MR16 LED	-AD = Advanced Diagnostics (audible)

Example: **CCTSM36-2**