

DATE:	LOCATION:
TYPE:	PROJECT:
CATALOG #:	

EVS Series

11" ROUND LED CEILING LIGHT

FEATURES

- Offered in AC only, AC and Emergency, with Heater Option
- Includes Self-Test , Self-Diagnostics
- 1200 Lumens in AC normally-On, and 350 Lumens in Emergency
- 4000K color temperature
- LED life-cycle of 50,000 hours
- Dual-voltage 120 or 277 VAC input, 50/60Hz.
- Emergency models designed for 90 minute runtime
- AC and Heater Option Models:-30°C to 40°C(-22°F to 104°F)
- Emergency Models: 0°C to 40°C(32°F to 104°F)



SPECIFICATIONS

APPLICATION

- The EVS is specifically designed for general illumination in residential and commercial applications for indoor/outdoor protected environments
- Emergency versions can be switched on/off along with the AC only fixtures for continuous lighting coverage
- Applications include multifamily dwellings with long hallways, apartment complexes and stairways

CONSTRUCTION

- Housing constructed of a high-strength steel with molded and frosted polycarbonate lens
- Emergency model includes battery compartment with removeable steel door

INSTALLATION

- Fixture ceiling mounts to a universal mounting plate(included) which is installed to a 3" single gang, 3 1/2", 4" octagon or 4" square electrical box
- Provided with pre-stripped leads for connection in j-box

ELECTRICAL

- 120 or 277VAC input, 50/60Hz
- Emergency version includes push-to-test, AC-on indicator with fault code display
- Emergency models supplied with a 9.6 VDC Lithium Iron Phosphate battery
- AC-only version includes 0-10V Dimming

OPTICS

- LED board contains 56 high-power LEDs rated for 50,000 hours which provide a bright and uniform light pattern
- Optics are diffused through a frosted polycarbonate lens
- LED efficacy 73 lm/w

COMPLIANCES

- UL924 Listed for Damp Locations
- AC models Energy Star Listed
- NFPA 101 and NFPA 70
- OSHA
- FCC Compliant
- CEC T20 Compliant

WARRANTY

- 5 year full unit warranty
- See [HLI Standard Warranty](#) for additional information

KEY DATA	
Lamp Color	4000K
Total Lamp Output	1200-AC 350-EM
System Efficacy (LPW)	73 LPW
Rated LED Lifecycle (Hours)	50,000

DATE:	LOCATION:
TYPE:	PROJECT:
CATALOG #:	

EVS Series

11" ROUND LED CEILING LIGHT

ORDERING GUIDE

Example: EVSBN

CATALOG #

Catalog Number	Description
EVSBN	Brushed Nickel, AC only, 1200 lumens
EVSDB	Dark Bronze, AC only, 1200 lumens
EVSW	White, AC only, 1200 lumens
EVSBN-E	Brushed Nickel, with LiFePO Battery, Self-Test/Self-Diagnostics
EVSDB-E	Dark Bronze, with LiFePO Battery, Self-Test/Self-Diagnostics
EVSWE	White, with LiFePO Battery, Self-Test/Self-Diagnostics
EVSBN-E-HTR	Brushed Nickel, with LiFePO Battery, Battery Heater(-30°C - 40°C), Self-Test/Self-Diagnostics
EVSDB-E-HTR	Dark Bronze, with LiFePO Battery, Battery Heater(-30°C - 40°C), Self-Test/Self-Diagnostics
EVSWE-HTR	White, with LiFePO Battery, Battery Heater(-30°C - 40°C), Self-Test/Self-Diagnostics

EMERGENCY PERFORMANCE

Single unit Coverage	Emergency Mode	
Mounting Height	9'	
Path Width	8'	
Indoor Reflectance	80/50/20	45'
Outdoor Reflectance	0/30/10	33'

Meets Life Safety Code minimum illuminance of 0.1 fc and average illuminance of 1.0 fc. Assumes open space with no obstructions, ceiling height of 9' and reflectance of 80/50/20. Photometry files available on the Dual-Lite website (www.dual-lite.com)

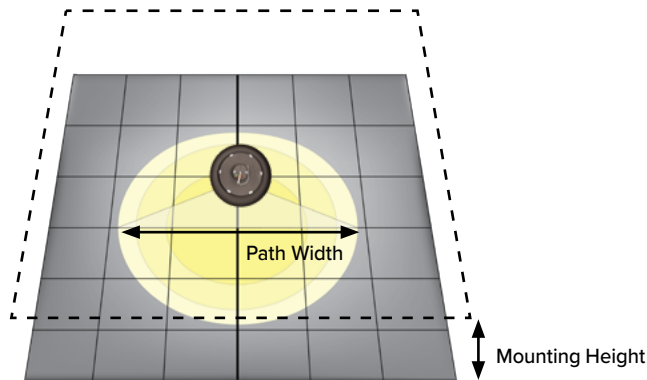

INPUT POWER REQUIREMENTS

	AC Version		EM Version with Heater		EM Version without Heater	
	Watts	Amps	Watts	Amps	Watts	Amps
120VAC	17W	0.14 A	29W	0.24A	22W	0.183A
277VAC	18W	0.08 A	30W	0.135A	23W	0.10A

ELECTRONICS

For the emergency model, upon failure of normal utility power, a microprocessor controlled switch automatically activates the emergency LED lamp heads. Upon resumption of normal utility power, the battery is disconnected from the load and recharged through a microprocessor-controlled pulse charger.

The battery is a maintenance-free Lithium iron phosphate battery type.

SELF-TEST/ SELF-DIAGNOSTICS

- External push-to-test switch and AC-on indicator
- Battery recharge within 24 hours
- AC Lockout circuit
- Low voltage battery disconnect
- For emergency models, Self-diagnostics monitors LED status, LED driver circuit, battery capacity and charger function and displays any fault detection by means of a flashing code
- Self-Test feature automatically runs a 1 minute test once a month and an alternating 30 or 60 minute test once every 6 months. Multicolor LED indicator provides visible fault detection and charging status
- User initiated 1, or 90 minute system test feature
- Automatic unit transfer in brownout conditions (below 80% of nominal AC input voltage)

DIMENSIONS

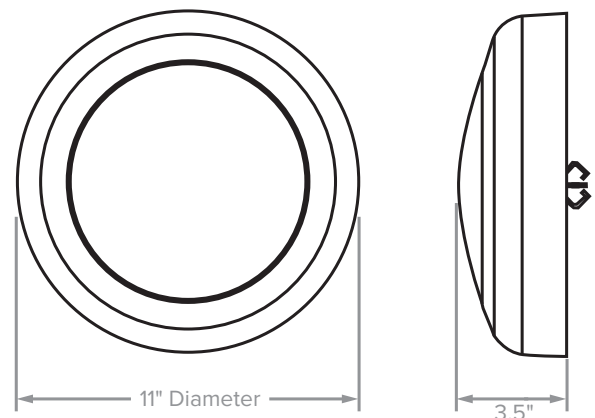

DATE: _____ LOCATION: _____

TYPE: _____ PROJECT: _____

CATALOG #: _____

EVS Series

11" ROUND LED CEILING LIGHT

PHOTOMETRY

EVSWE-HTR - AC OPERATION

LUMINAIRE DATA

Test No.	20.00971
Description	EVSWE-HTR; AC Test w/ Plastic Refractor
Watts	17.6
Efficacy	64.5 lm/W
Mounting	ceiling
Spacing Criterion	1.28

ZONAL LUMEN SUMMARY

Zone	Lumens	% Luminaire
0-40	470	25.1
0-60	843	74.2
0-90	1119	98.6
0-180	1135	100.0

POLAR GRAPH

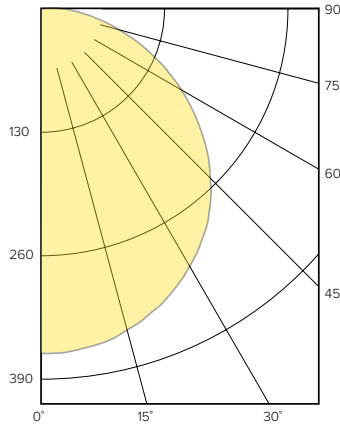

CANDELA DISTRIBUTION

Angle	Candela
0	363
5	362
15	350
25	328
35	296
45	252
55	199
65	142
75	85
85	40
90	24

EVSWE-HTR - EMERGENCY OPERATION

LUMINAIRE DATA

Test No.	20.00972
Description	EVSWE-HTR; Emergency Test w/ Plastic Refractor - 48 hr. battery charge
Watts	NA
Efficacy	21.5 lm/W
Mounting	ceiling
Spacing Criterion	1.28

ZONAL LUMEN SUMMARY

Zone	Lumens	% Luminaire
0-40	157	41.4
0-60	281	74.3
0-90	373	98.5
0-180	378	100.0

POLAR GRAPH

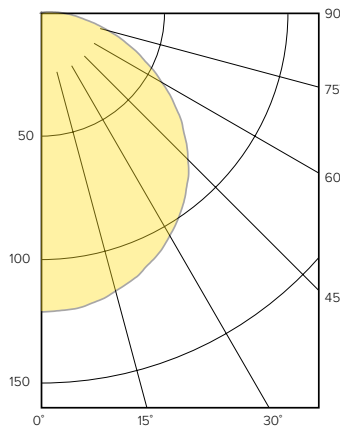

CANDELA DISTRIBUTION

Angle	Candela
0	121
5	121
15	117
25	109
35	99
45	84
55	67
65	47
75	28
85	14
90	8