



PROJECT: _____
 FIXTURE TYPE: _____
 LOCATION: _____
 CONTACT/PHONE: _____

DESCRIPTION

Designed for mounting heights up to 30 ft. or more, this LED fixture produces over 860 lumens with dual optical lenses to produce a wide, elongated beam along the path of egress. With installed spacing of 50 ft. in a ceiling of 30 ft., an average of 1 Footcandle is easily achieved.

PRODUCT FEATURES

- Emergency lighting with optional dual function operation for night or security lighting.
- Housing constructed from rugged extruded aluminum
- Very low power consumption in optional night/ security mode. The security lighting circuit is independent of emergency lighting and may be switched manually, by an exterior photocell, or other automatic means.
- Over 50,000 hour lamp life in normal use.
- Universal 120/277 VAC input
- IES photometric data available for all models.
- Manufactured and tested to UL Standard 924 and NFPA Life Safety Code 101.
- Made in the USA
- 5 year warranty



MOUNTING DATA & DIMENSIONS

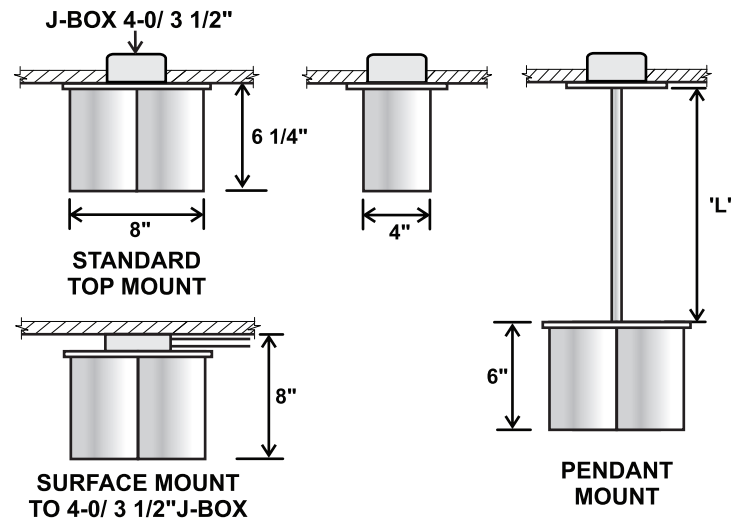

ORDERING INFORMATION

MODEL	OPERATION	WATTS	HOUSING COLOR	OPTIONS
ELSD	BB= Battery Backup	Battery Backup Models	W = White	DP= Damp Location
	AC = AC Supply 120/277	14= 14 Watts	X = Custom	DG= Battery Diagnostics (BB Models Only)
		20= 20 Watts		SMJ= Surface Mount to J-Box
		AC Models		SB120= Security Lighting with Control Switch for Standard BB Operation (120V)
		8 = 8 Watts		SD277= Security Lighting with Control Switch for Standard BB Operation (277V)
		14 = 14 Watts		SD= Security Lighting with Control Switch for BB Operation with
				P12= 12" Pendant Mt (Std.)
				Custom Size:
				PL= L" Pendant Length- Max Length 96"

Ordering Example: ELSD-BB-14-W-DP

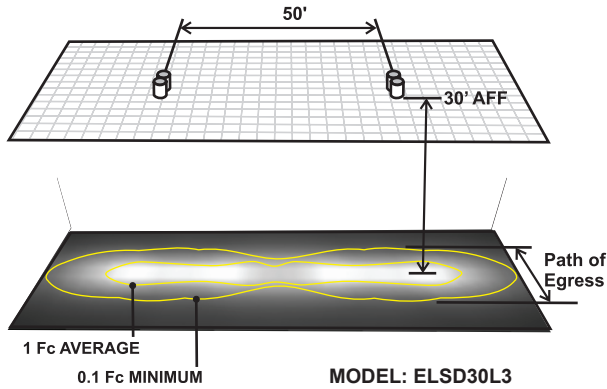

SPACING GUIDE

Model	Mtg. Ht.	SPACING	
		Path of Egress Width	
		3 Ft.	10 Ft.
14 W	30'	35'	N/A
20W	30'	50'	35'

NOTE: TESTED IN ACCORDANCE WITH IES STANDARD LM-79-08 FOR SOLID STATE LIGHTING PRODUCTS. FOR REFERENCE ONLY. STANDARD REFLECTANCES 80/50/20. Mule IS NOT RESPONSIBLE FOR SPECIFIC CONDITIONS THAT MAY ALTER THE RESULTS. COMPLETE IES PHOTOMETRIC DATA AVAILABLE AT www.mulelighting.com FOR YOUR CONVENIENCE.

SECURITY LIGHTING CONTROL

BB Models: Requires Option '-SB120' for connection to 120 VAC
 Requires Option '-SD277' for connection to 277 VAC

BB-DG Models: Requires Option '-SD' for connection to 120/ 277 VAC

CONSTRUCTION

- Housing and canopy plate from rugged extruded aluminum.
- Mounts cleanly to ceiling, or direct to j-box for exposed conduit applications, such as unfinished ceilings.
- Standard satin white finish; custom paint or satin anodized finishes are also available.

ELECTRONICS

- Lamps are connected in parallel. If one lamp fails, one or more lamps will continue in operation.
- Universal 120/277 VAC input for standard battery
- Power supply delivers regulated current and voltage to LED lamps at optimum levels to maximize lamp life.
- Automatic battery diagnostics available for all battery models.

WARRANTY

- 5 year total customer satisfaction warranty. For details see product catalog technical data section.

SUGGESTED SPECIFICATIONS

Install ELSD Surface Mount LED down light emergency lighting fixture manufactured by Mule Lighting Inc. Upon loss of AC building power, emergency models shall operate for a minimum of 90 minutes in compliance with UL 924 and NFPA LSC Code 101. The unit may be specified to operate continuously for security or night lighting, as required. The battery charger and power supply shall have universal input of 120/277 VAC, with brownout and LVD circuit protection. Auto battery diagnostics shall be available for all models, as specified and shall perform all test functions specified by UL 924 and NFPA 101.

SELF- TEST DIAGNOSTIC FUNCTIONS

BB MODELS WITH DG FUNCTION

STATUS	LED DISPLAY
NORMAL FULL CHARGE	GREEN ON
NORMAL FAST CHARGE	ORANGE ON
FAILED BATTERY	RED FLASH FAST
FAILED LAMP	GREEN FLASH
FAILED TRANSFER	ORANGE FLASH
FAILED CHARGER	RED FLASH SLOW