



FHEX23



Recessed Aluminum LED Edgelit Exit

- Push-to-test switch
- LED charge indicator
- AC and EM models
- Field applied chevron directional indicators
- Maintenance-free, 6V sealed lead-acid battery
- Compatible with drop ceiling mount installations. Bar hangers included
- Energy saving LED lamp source
- Dual voltage 120V/277V
- UL Listed in accordance with UL924
- Ideal for stores, offices, hospitals and school corridors.

General Specifications

	FHEX23 (Red)	FHEX23 (Green)
Input Voltage	120/277VAC	120/277VAC
Input Current (120V)	148mA	148mA
Input Current (277V)	133mA	131mA
Input Power (120V)	3.2W	3.0W
Input Power (277V)	3.0W	2.8W
Operating Frequency	60Hz	
Operating Ambient Temperature Range (Ta)	0°C to 50°C / 32°F to 122°F	
Overall Size	12.6" L x 8" H	
Emergency Operation	90 minutes	
Compliance	UL 924 Listed Damp Location	
Warranty	5 years from the date of manufacture	

Mechanical Data

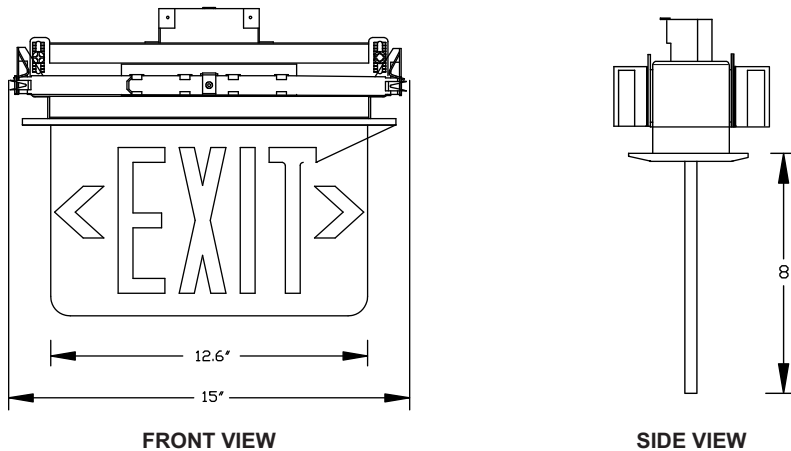

Part Number Matrix

FHEX23

A

S

R

EM

Case Color
A = Aluminum
W = White
B = Black

Number of Faces
S = Single
D = Double

Letter Color
R = Red
G = Green

Operation
AC = AC Only
EM = Battery Backup