



MODEL NO: _____
 TYPE: _____
 PROJECT: _____
 COMMENTS: _____

INITIAL LUMEN OUTPUT
 3000 Lumens

LAMPS OPERATED*

- (2) 2-4 ft. T8, T12
- (2) 28 or 54W T5
- (2) 24W-50W Long Compact
- Select LED Retrofit Tubes

*Refer to Lumen Reference Chart and LED Retrofit Reference Chart for list of compatible lamps.

DESCRIPTION

The **I162R** from IOTA Engineering is a UL Listed fluorescent emergency ballast that allows the same fixture to be used for both normal and emergency operation. In the event of a power failure, the **I162R** switches to the emergency mode and operates **one or two** of the existing lamps for **90 minutes**. The unit contains a battery, charger, and inverter circuit in a single can and is provided with 2 feet of 1/2" flex for wiring to the fixture. The unit is designed for mounting in the ceiling grid, and comes integrated with the recess mounting pan for installation. The **I162R** can be used with most **2'-4' lamps**, with an initial output of up to 3000 lumens for one or two lamps, **and utilizes AC output to ensure compatibility with new lamp technologies**. The unit features lamp selector leads for optimizing light output for designated lamp types. The **I162R** is suitable for use in damp locations.

SPECIFICATIONS

Input Voltage	(Dual) 120/277V, 60Hz
Input Wattage	4.5 Watts
Lamps Operated	Most 2'-4' single, bipin T8 and T12, 28W or 54W T5, and 24W-50W long compact fluorescent lamps
Emergency Operation	(2) 2'-4' T8 and T12, (2) 28W or 54W T5, or (2) 24W-50W long compact lamps
Initial Illumination	(2) lamps 3000 lumens 1500 lumens each lamp
Operating Temp	0° to 50° C
Battery	24 Hour Recharge 7-10 Year Life Expectancy
Weight	9 lbs.
Approval	UL and CUL 924 Listed



DIMENSIONS

23.375" x 3.0" x 3.0"

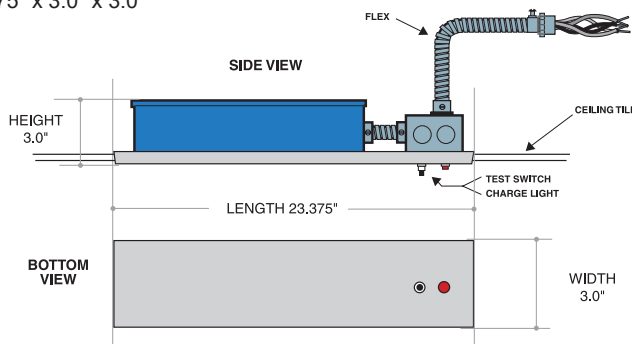

PRODUCT ADVANTAGES

- **Parallel Lamp Operation**
- **3000 Lumen Output**
- **Recess Mounting Pan Configuration**
AC output for compatibility with Low-Mercury Content Amalgam lamps
- **Time Delay feature for compatibility with End-of-Lamp-Life circuitry**
- **Open Circuit Isolation protects unit when load is absent**

FEATURES

- Will cold start and operate all specified lamps
- Long life high temperature recyclable Ni-Cad battery
- Painted steel case
- Includes test switch and charge indicator accessory kit
- For use with switched or unswitched fixtures
- **5-Year Warranty**
- Suitable for use in damp locations and plenum fixtures.
- Meets or exceeds all NEC, IBC, and Life Safety Code Emergency Lighting Requirements
- RoHS Compliant

FLUORESCENT

LINEAR



I162R

FLUORESCENT EMERGENCY BALLAST WITH RECESS MOUNTING PAN

INITIAL LUMEN RATINGS

LAMP	2 LAMPS
F28 T8	2700
F32 T8	3000
F40 T12	2675
28W T5	2400
54W T5	2500
24W Long Compact	1120
25W Long Compact	1485
39W Long Compact	1450
40W Long Compact	1900
50W Long Compact	1900

LED Retrofit Tube Options

This IOTA Emergency Ballast is UL Listed for emergency operation of select LED retrofit tube applications. For a complete list of acceptable LED retrofit tube options, refer to the **IOTA LED Retrofit Tube Reference Chart** at www.iotaengineering.com/IOTA-LED-Retrofit.pdf

I162R SAMPLE SPECIFICATION

Emergency lighting shall be provided by using a standard fluorescent fixture equipped with an **IOTA I162** fluorescent emergency battery pack. The **I162** shall consist of a high temperature, maintenance-free nickel cadmium battery, charger board and an electronic circuit enclosed in a 16.375" x 3.0" x 3.0" vandal-resistant painted steel case for installation either adjacent to or on top of the fixture. A long-life LED charge indicator light and test switch shall be included. The fluorescent EM pack shall operate **two** 20W-40W (2'-4') T8 - T12 fluorescent lamps, **two** 28W or 54W T5, or **two** 24W-50W long compact fluorescent lamps in **PARALLEL OPERATION**. The **I162** shall provide reduced illumination for a minimum of 90 minutes in the emergency mode with a total initial output of 3000 lumens and **will operate the lamps with AC output**. Should one lamp become inoperable, the remaining lamp shall operate at a minimum initial output of 2000 lumens. The **I162** shall have 4.5 watts of input power and a battery capacity of 48 watt hours. The **I162** is UL Listed and meets or exceeds all NEC and Life Safety Code Emergency Lighting Requirements, and rated for use in damp locations. The **I162** is warranted for a full five (5) years from the date of purchase.

3000 LUMEN SAMPLE SPECIFICATION

Emergency lighting shall be provided by using a standard fluorescent fixture equipped with a fluorescent emergency battery pack. The EM pack shall consist of a high temperature, maintenance-free nickel cadmium battery, charger board and an electronic circuit enclosed in a painted steel case for installation either adjacent to or on top of the fixture. A long-life LED charge indicator light and test switch shall be included. The fluorescent EM pack shall operate **two** 20W-40W (2'-4') T8 - T12 fluorescent lamps, **two** 28W or 54W T5, or **two** 24W-50W long compact fluorescent lamps in **PARALLEL OPERATION**. The EM pack shall provide reduced illumination for a minimum of 90 minutes in the emergency mode with a total initial output of 3000 lumens and **will operate the lamps with AC output**. Should one lamp become inoperable, the remaining lamp shall operate at a minimum initial output of 2000 lumens. The unit shall have 4.5 watts of input power and a battery capacity of 48 watt hours. The EM pack must be UL Listed and meet or exceed all NEC and Life Safety Code Emergency Lighting Requirements, and rated for use in damp locations. All product shall be warranted for a full five (5) years from the date of purchase.

REMOTE MOUNTING

When battery packs are remote mounted, consult Customer Service for the maximum allowable distance between the battery pack and lamp(s).

Warranty: 5-Year Limited Warranty

Complete warranty terms located at www.acuitybrands.com/CustomerResources/Terms_and_conditions.aspx