

Job/Location: \_\_\_\_\_  
 Contractor: \_\_\_\_\_  
 Prepared By: \_\_\_\_\_

Job Type: \_\_\_\_\_  
 Date: \_\_\_\_\_

Standard lamp heads are constructed of high impact thermoplastic in a black color. The PAR36 large style head features a unique locking twist collar that securely holds the lens and facilitates quick and easy re-lamping

The JC can be used in areas that generate dust, lint, fibers, dripping water and condensation.

**Installation:** : The LDT is suitable for surface wall mounting. Designed and approved for NEMA 12 required installations.

**specifications: internal**

The JC is an industrial grade 6, 12 and 24 volt emergency lighting unit, designed for durability and dependability. Configured with 120/277VAC input with a solid state charging system that offers superior performance and energy efficiency. Weatherproof PAR36 emergency lighting heads are installed on the unit standard. Other features include low voltage disconnect, AC lockout and brownout protection.

**specifications: external**

The JC is constructed with a 16 gauge steel cabinet. Terminal connectors allow for larger gauge wires to be connected for remote loads. Industrial gray powder coat finish is standard. The PAR36 style emergency lighting heads are molded from high impact thermoplastic.



Designed with a maintenance free, sealed valve regulated lead acid battery that provides a minimum emergency duration of 90 minutes

External test switch and monitor LED are standard

Housing: Heavy duty 16g steel NEMA 12 gasketed housing finished in an industrial gray powder coat.

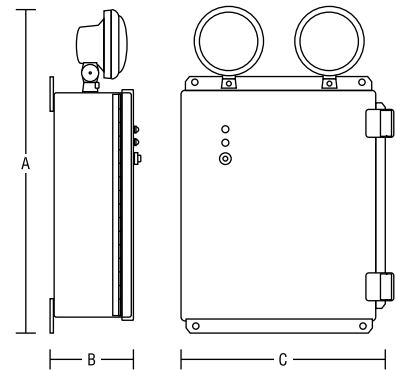

| Cabinet | A            | B           | C            |
|---------|--------------|-------------|--------------|
| A       | 12"<br>305mm | 5"<br>127mm | 10"<br>254mm |

**ordering logic**

| ? aVW | Volts    | Watts Pb-A Battery | Emergency Heads   | Lamps <sup>1</sup> | Options                            |
|-------|----------|--------------------|-------------------|--------------------|------------------------------------|
| JC    | 6 (6V)   | 27 (6V)            | 0 (no heads)      | (see lamp chart)   | SD (self diagnostics)              |
|       | 12 (12V) | 36 (6V, 12V)       | 2 (2 PAR36 heads) |                    | NC (nicad battery)                 |
|       |          | 60 (6V, 12V)       |                   |                    | TD <sup>2</sup> (time delay relay) |
|       |          | 72 (6V)            |                   |                    | AM (ammeter)                       |
|       |          | 120 (6V, 12V)      |                   |                    | VM (voltmeter)                     |
|       |          | 140 (12V)          |                   |                    | IRT (infrared remote testing)      |
|       |          |                    |                   |                    | FP (food prep lens)                |

<sup>1</sup>Specify desired lamp type and wattage from lamp selection chart

<sup>2</sup>Must specify 5, 10 or 20 mins and AC Voltage (10 mins standard)

EXAMPLE: JC-6-36-2-6VSBH-8W-SD  
 DESCRIPTION: JC Emergency Unit,, 6VDC, 36 Watts, sealed lead battery, two PAR36 heads, 8 watt sealed beam halogen lamps, self diagnostics

## ■ specifications: electrical

**43FF7DK:** The JC is designed with a maintenance free, sealed valve regulated lead acid battery that provides a minimum emergency duration of 90 minutes (for the listed rating). Recharge time of the battery is less than 48hours. The maximum working temperature is 45° C. The minimum working temperature is 10°C. Nickel cadmium batteries are available as an option.

**5;D5G;F:** The JC utilizes a high-efficiency two stage charger providing precise float voltage control with low voltage disconnect protection. All components used in the circuitry are temperature compensated. The charger also has brownout and short circuit protection. Charger status is easily determined via a dual diagnostic LED display which indicates AC/ON and High Charge. An external push button test switch allows maintenance personnel to quickly determine the operational status of the unit and lamp load.

## ■ specifications: mechanical

The JC is constructed with a 16 gauge steel cabinet. Industrial gray powder coat finish is standard. Emergency lighting heads are molded from high impact thermoplastic. The JC features integrated mounting feet that ensure positive and secure installations. External test switch & monitor LED are standard.

## ■ specifications: self diagnostics

The Mule Autotest system (optional) performs one 5 minute discharge test monthly. Every 6 months two 90 minute discharge tests are performed. This tests both full battery capacity and recharge capability, as required by the fire code. The information is communicated simply and intuitively to maintenance personnel via a single multi-color LED. The Mule Autotest system also includes 0, 5, 10 or 20 minute time delay function to allow HID lighting to restrike. IRT (optional) one button press tests unit for 90 minutes per code.

- Red: Battery or Circuit Malfunction
- Yellow: Lamp Malfunctioning
- Green: Normal Operation

## ■ warranty

The JC Series comes with a 3-year factory warranty. Lamps are not covered under the warranty. batteries have a 1 year warranty. Deliberate damage, misuse, improper installation effectively cancel the warranty.

## ■ lamp selection

|                           | 6V                               | 12V                                |
|---------------------------|----------------------------------|------------------------------------|
| Incandescent              | 9, 12, 25W<br>(18W - PAR36 Only) | 9, 12, 18W<br>(25W - PAR36 Only)   |
| Halogen (H)               | 8, 10, 12, 20W                   | 8, 12, 20, 35W<br>55W (PAR36 Only) |
| Sealed Beam Tungsten (SB) | 8, 12, 18,<br>25, 30W            | 12, 18, 25,<br>30, 35, 50W         |
| Sealed Beam Halogen (HSB) | 8, 12, 20W                       | 8, 12, 30W                         |

## ■ model rating guide

| Model     | Voltage | Wattage |        |        |        |
|-----------|---------|---------|--------|--------|--------|
|           |         | 90min   | 120min | 180min | 240min |
| JC-6-22   | 6       | 22      | 17     | 11     | 9      |
| JC-6-27   | 6       | 27      | 20     | 14     | 10     |
| JC-6-36   | 6       | 36      | 27     | 18     | 13     |
| JC-6-42   | 6       | 42      | 31     | 21     | 15     |
| JC-6-54   | 6       | 54      | 41     | 27     | 21     |
| JC-6-60   | 6       | 60      | 45     | 30     | 22     |
| JC-6-72   | 6       | 72      | 54     | 36     | 27     |
| JC-6-90   | 6       | 90      | 60     | 45     | 30     |
| JC-6-120  | 6       | 120     | 90     | 60     | 45     |
| JC-12-36  | 12      | 36      | 27     | 18     | 13     |
| JC-12-42  | 12      | 42      | 31     | 21     | 15     |
| JC-12-60  | 12      | 60      | 45     | 30     | 22     |
| JC-12-90  | 12      | 90      | 60     | 45     | 30     |
| JC-12-130 | 12      | 130     | 97     | 65     | 48     |
| JC-12-140 | 12      | 140     | 105    | 70     | 52     |
| JC-24-100 | 24      | 100     | 75     | 50     | 25     |

NOTE: Cabinet size may change based on configurations.