



New and Existing Construction

LB6LEDA10L

LED Downlight Module (1000 Lumens)
 12W High Efficacy
 Wet Location
 120V



LiteBox 6"

Aperture: Nominal 6"
 See Housing Specification Sheet for ceiling cutout requirements
 Not to Scale

APPLICATIONS:

LiteBox LED modules are designed for use in new construction as well as retrofit applications with existing Prescolite or competitive 6" housings using the screw base adapter included. Lumen output and distribution comparable to a 75W PAR while consuming only 12 watts. ENERGY STAR® qualified. Can be used to comply with California Title 24 IECC watts per square foot requirements. Suitable for use with continuous room side ambient temperature up to 25°C. Flicker-free dimming to 15% with most standard dimmers. (See Dimming Notes).

LIGHT ENGINE:

High efficacy LED light engine, 3000K and 3500K, 80+ CRI, integrated with durable aluminum heat sink for excellent thermal management. System designed for optimal life and lumen maintenance (60,000 hours at 70% lumen maintenance per TM-21).

LENS/REFLECTOR:

All LiteBox LED modules are provided standard with a diffuse optical grade acrylic lens for uniform illumination and superior glare control. Reflector powder coat finish creates aesthetic ceiling appearance and visually comfortable 55° cutoff.

LED DRIVER:

Integral high efficiency LED driver 120V, >0.9 power factor, dimmable to 15% with standard incandescent or electronic low voltage dimmers. (See Dimming Notes for recommended dimmers.) Output over-voltage, over-current, and short circuit protection. Life expectancy of 60,000 hours minimum at recommended ambient temperatures.

INSTALLATION:

For New Construction: Use with Prescolite DBX QuickLink LED housings. QuickLink connector mates directly to housing connector without a screw base adapter for California Title 24 compliance.

For Retrofit: Use in Prescolite or other compatible 6" recessed housings using supplied screw base adapter.

Easy installation with (3) stainless steel spring clips (pre-installed).

CERTIFICATIONS:

UL/cUL Classified for use in Prescolite or other 6" recessed housings including Halo, Juno, and Lithonia. (See page 3 for more details) Suitable for wet locations. ENERGY STAR qualified. Meets California Title 24 with DBXQL

WARRANTY:

5 year warranty
 Additional information on page 3
 See www.prescolite.com for details.

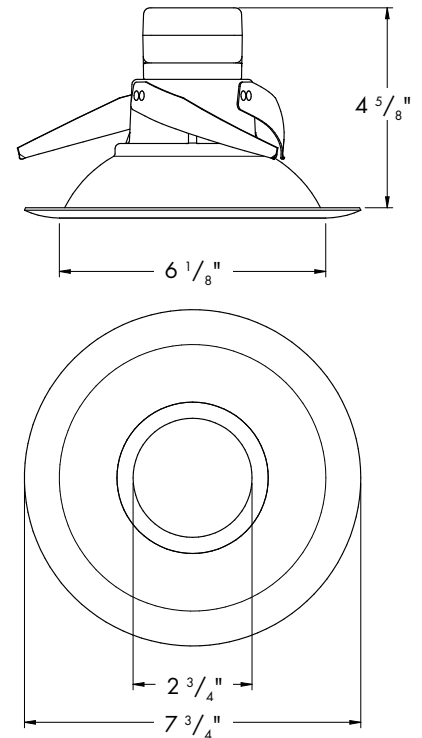

CATALOG NUMBER

EXAMPLE: LB6LEDA10L30K WH

TRIM	LED COLOR	CRI	TRIM COLOR	ACCESSORIES
<input type="checkbox"/> LB6LEDA10L 6" 1000 Lumen Litebox LED Module with dimming to 15% 120V	<input type="checkbox"/> 30K 3000 Kelvin <input type="checkbox"/> 35K 3500 Kelvin	<input type="checkbox"/> Blank 80+ CRI	<input type="checkbox"/> WH White <input type="checkbox"/> BL Black <input type="checkbox"/> Z Zet <input type="checkbox"/> BZ Bronze	<input type="checkbox"/> LiteGear¹ Inverter, single phase central lighting, 125VA-250VA <input type="checkbox"/> LPS Series¹ LitePower micro-inverter, 20VA-55VA <input type="checkbox"/> DBXQL IC/Non-IC Airtight housing with supply wire quick connects

¹ See Central Inverter compatibility note and web links on page 2.

PHOTOMETRIC DATA

Litebox LED - 6" LED Downlight Module

ELECTRICAL DATA	LB6LEDA
Input Voltage	120V
Input Frequency	43-63 Hz
Input Current	0.10A
Input Power	12.0W
Constant Current Output	700mA
Power Factor	>0.90
THD	<20%
EMI Filtering	FCC 47CFR Part 15, Class B
Operating Temperature	-30°C to 60°C
Dimming	Yes*
Over-voltage, over-current, short-circuit protected	
*See Dimming Notes for more information	

LB6LEDA10L35K WH

LED Light Engine: 3500K 83 CRI
System Wattage: 12
Fixture delivered lumens: 1038
Fixture Efficacy: 87.0
Spacing Criteria: 1.1

Single Unit, Initial Footcandles, 30" Work Plane							Ceiling to Floor Height (ft)	Multiple Units, Initial Footcandles, 30" Work Plane			
Nadir	10°		20°		30°			Spacing is Maximum Over Work Plane, SMH= 1.1			
FC	FC	Dia (ft)	FC	Dia (ft)	FC	Dia (ft)	Fixture Spacing (ft)	RCR 2	RCR 5	RCR 7	
52	48	1	37	3	24	4	6	4.0	69	51	43
21	19	2	15	4	10	6	8	6.0	28	21	18
10	9	3	7	6	5	9	10.5	9.0	13	10	8
7	6	3	5	7	3	11	12	10.0	9	7	6

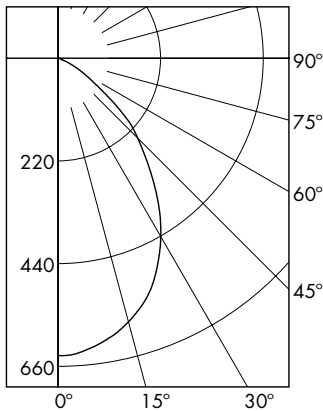

CANDELA DISTRIBUTION	
DEG	CANDELA
0	634
5	630
15	588
25	504
35	384
45	257
55	129
65	41
75	8
85	3
90	0

ZONAL LUMEN SUMMARY

ZONE	LUMENS	%LUMINAIRE
0-30	451	43.5%
0-40	683	65.9%
0-60	986	95%
0-90	1038	100.0%

COEFFICIENTS OF UTILIZATION

Zonal Cavity Method

Room Cavity Ratio	% Effective Ceiling Cavity Reflectance									
	80% 70% 50% 30%									
	20% Effective Floor Cavity Reflectance									
	% Wall Reflectance									
	70	50	30	0	70	30	50	20	50	20
1	112	108	105	102	109	103	102	97	98	94
3	97	89	82	77	95	81	84	75	82	74
5	84	73	66	60	82	65	70	59	68	59
7	73	62	54	49	72	54	60	48	58	48
9	65	53	46	41	63	45	51	40	50	40

LB6LEDA10L35K WH

Test No. CSA 2585298

Test No. CSA 2585298

Tested at 25°C Ambient in accordance to IESNA LM-79-2008

Central Inverters

For full fixture output in back-up mode, we recommend you visit www.dual-lite.com for your Central Lighting Inverter options. Please contact your local Hubbell representative for any assistance with proper sizing and loading of your inverter selection. Central lighting inverters must be ordered separately.

LiteGear: www.dual-lite.com/products/litegear_lg_series

LPS Series: www.dual-lite.com/products/lps

NOTES

Refer to www.prescolite.com for additional photometric tests (IES Files).



Web: www.prescolite.com • Tech Support: (888) 777-4832
701 Millennium Boulevard • Greenville, SC 29607 U.S.A. • Phone (864) 678-1000
Copyright ©2016 Prescolite, Inc., a division of Hubbell Lighting, Inc. All Rights Reserved
Specifications subject to change without notice. • Printed in U.S.A. • LB-LED-009 • 7/27/16



HUBBELL
Lighting, Inc.

DIMMING NOTES:

LiteBox LED integral driver is compatible with existing 2-wire dimming circuits and is designed to operate with most standard dimmers including incandescent 120V line voltage (forward phase-leading edge) dimmers as well as 120V electronic low voltage (ELV) (reverse phase-trailing edge) dimmers. Dimming capabilities will vary depending upon the dimmer control used.

A 120V Electronic Low Voltage (ELV) dimmer can typically operate a single LED unit and are recommended for use with LB6LEDA Series.

Recommended Electronic Low Voltage Dimmers:

- Lutron Nova T Series (Part number NTELV-600)
- Lutron Faedra (Part Number FAELV-T00-XX)
- Leviton Acenti (Part Number ACE06-XXX)
- Leviton Vizia (Part Number VZE04)

Most incandescent line voltage dimmers have minimum load requirements of approximately 40W and may require multiple LED modules per control. (See dimmer control manufacturer's instructions for specific requirements.)

Recommended Incandescent Line Voltage Dimmers:

- Leviton, Illumitech Series (Part Numbers IPI06-XXX)
- Leviton, Trimatron Series (Part Numbers 6602-X, 6681-X, 6683-X, 6684-X, 700-X and 705-X)
- Leviton, SureSlide Series (Part Numbers 6631)
- Leviton, True Touch Series (Part Number 66061LM)
- Lutron Skylark Series (Part Number S-600, S2-LH)
- Lutron, Maestro Sereis (Part Numbers MAW-600)
- Cooper, Aspire Series (Part Numbers 9530XXX)

Digital dimmers are not compatible with LiteBox LED modules.

COMPATIBILITY OF 6" RECESSED HOUSINGS:

LiteBox LED modules are UL/cUL classified for use with Prescolite and most competitive recessed cans (with "A" and "B" dimensions) including:

Prescolite	Lithonia
Capri	Lumapro
Commercial Electric	Luminaire
Elco	Nora
Emerald	Progress
Halo	Sea Gull
Intense	WAC
Jimway	
Juno	

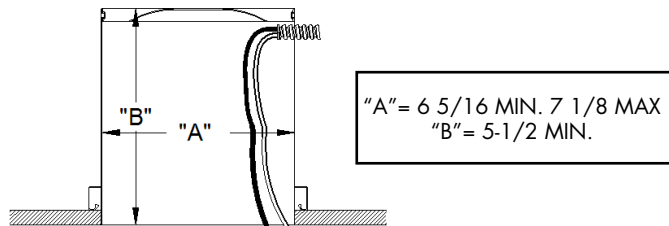

LED lighting facts
A Program of the U.S. DOE

Light Output (Lumens)	1037
Watts	12
Lumens per Watt (Efficacy)	87

Color Accuracy Color Rendering Index (CRI)	83
---	----

Light Color Correlated Color Temperature (CCT)	3341 (Bright White)
---	---------------------

2700K 3000K 4500K 6500K

All results are according to IESNA LM-79-2008: Approved Method for the Electrical and Photometric Testing of Solid-State Lighting. The U.S. Department of Energy (DOE) verifies product test data and results.

Visit www.lightingfacts.com for the Label Reference Guide.

Registration Number: TH94-5EVCD0W (1/24/2013)
Model Number: LB6LEDA10L3SK WH
Type: Recessed downlight

NOTES

1. Operation in ambient temperatures higher than those specified will shorten life and void warranty.
 2. Warranty is limited to repair and replacement of defective parts of the LED system and does not include labor or installation.
- See www.prescolite.com for details.



Web: www.prescolite.com • Tech Support: **(888) 777-4832**
 701 Millennium Boulevard • Greenville, SC 29607 U.S.A. • Phone (864) 678-1000
 Copyright ©2016 Prescolite, Inc., a division of Hubbell Lighting, Inc. All Rights Reserved
 Specifications subject to change without notice. • Printed in U.S.A. • LB-LED-009 • 7/27/16

