



# RADIUS SERIES - MRD-WL

COMMERCIAL GRADE WET LOCATION EMERGENCY LIGHT



PROJECT: \_\_\_\_\_  
 FIXTURE TYPE: \_\_\_\_\_  
 LOCATION: \_\_\_\_\_  
 CONTACT/PHONE: \_\_\_\_\_

## PRODUCT DESCRIPTION

The Mule MRD-WL is ideal for wet locations, resistant to corrosive atmospheres, non-hazardous dust environments, and to water spray, splashing water or hose down locations. The adjustable halogen lamps are enclosed in a fully gasketed, corrosive resistant fiberglass enclosure designed to withstand the harshest environments.

## PRODUCT SPECIFICATIONS

### CONSTRUCTION

Injection molded, engineering-grade, UV-retardant thermoplastic • UL94V-0 flame rating • Impact, scratch, and corrosion-resistant • Snap-fit housing and mounting plate • Universal mounting plate with quick-connect feature reduces installation labor • Fully gasketed clear polycarbonate cover offers protection against wet, non-hazardous dust, corrosive atmospheres, water spray and splashing water.

### ELECTRICAL

Dual 120/277 voltage standard • Rated for use in damp locations • Solid state charging and switching • Brownout protection • Battery low voltage disconnect • Overload and short circuit protection • AC power indicator and test switch.

### LAMPS

Supplied with 6V, 5W halogen MR16 lamps • Optional 3.3W or 5.0W LED lamps

### HEADS

Includes two adjustable lighting heads • Contemporary semi-recessed round head design • High performance chrome-plated metallized reflector and plastic lens for optimal light distribution • Adjustable lamp heads provide optimal center-to-center spacing.

### BATTERY

Maintenance-free 6V sealed lead calcium battery • Standard battery will operate fixture for a minimum of 90 minutes in the event of a power outage

### CODE COMPLIANCE

UL924 • UL Listed for wet locations (20°C – 40°C) • NFPA 101 Life Safety Code compliant • NEC and OSHA compliant

### WARRANTY

5-year warranty on housing and electronics. 1-year on battery. Product specifications subject to change without notice.

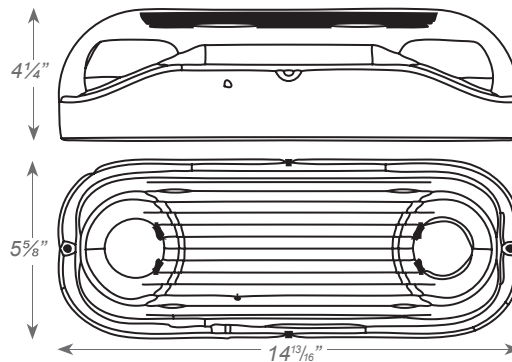

## INSTALLATION

### MOUNTING

Suitable for wall or ceiling mounting • Surface mount via knockouts on back of housing.

## ORDERING INFORMATION

model	options
MRD-WL	IH <sup>1</sup> = Internal Heater
	IHB <sup>2</sup> = Internal Heater w/ Battery Blanket
	LED = 3.3W High Lumen LED Lamps
	PLED = 5.0W High Lumen LED Lamps
	BL = Black Housing
NOTES:	USA = Assembled in USA

<sup>1</sup>Internal heater for cold temperature applications (-9°C – 40°C)

<sup>2</sup>Internal heater and battery blanket for extreme cold temperature applications (-25°C – 40°C)

Ordering Example: MRD-WL-IH



# RADIUS SERIES - MRD-WL

COMMERCIAL GRADE WET LOCATION EMERGENCY LIGHT



PROJECT: \_\_\_\_\_  
 FIXTURE TYPE: \_\_\_\_\_  
 LOCATION: \_\_\_\_\_  
 CONTACT/PHONE: \_\_\_\_\_

## PHOTOMETRICS

6V, 5W Halogen MR16 Lamp, MR16 Head

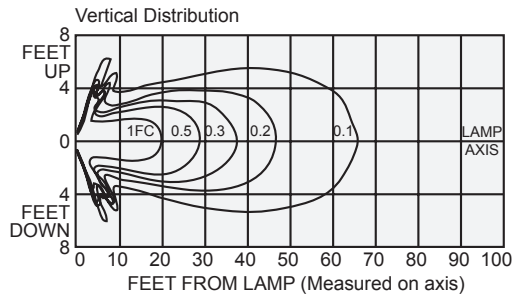
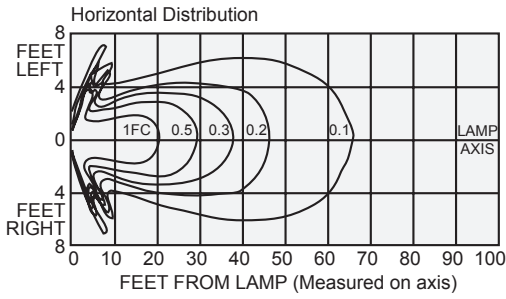

## SPACING DIAGRAMS

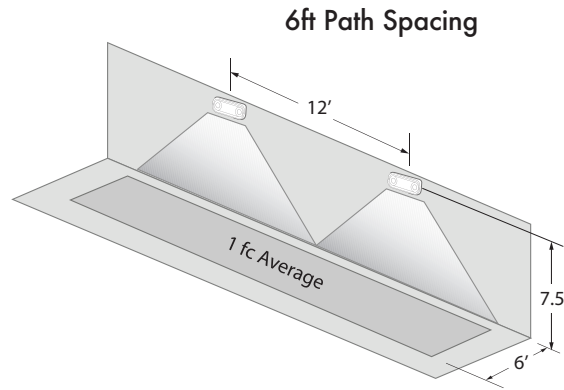
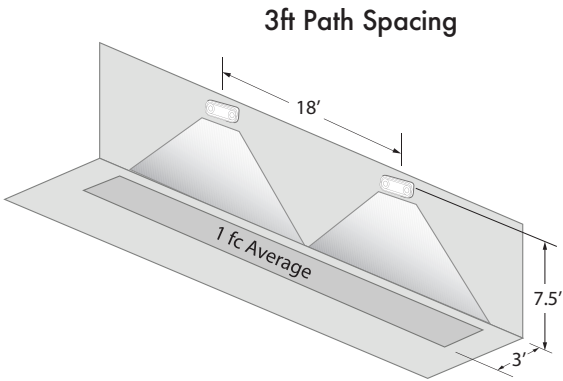

## BATTERY DATA

- Lead Calcium battery warranted for one full year .
- Recharges in 24 hours or less

Type	Battery Voltage	Shelf Life <sup>1</sup>	Expected Life <sup>1</sup>	Temperature Range <sup>2</sup>
Lead Calcium (std.)	6V, 4.5Ah	15 months	5-8 years	40°F-95°F
Lead Calcium with Warmer	6V, 4.5Ah	15 months	5-8 years	15°F-104°F

<sup>1</sup> At 77°F

<sup>2</sup> To obtain rated life and capacity.

## ENGINEERING DATA

	Input Voltage	Max. Amps	Max. Watts
Standard Unit	120	0.06	6.0
	277	0.03	6.2
With Battery Warmer	120	0.15	16.5
	277	0.12	17.5