



MODEL NO: _____
 TYPE: _____
 PROJECT: _____
 COMMENTS: _____

LUMEN PERFORMANCE

Fixture Efficacy	Minute 1	Minute 45	Minute 90
100 lm/W	1200	1200	1200
110 lm/W	1320	1320	1320
120 lm/W	1440	1440	1440
130 lm/W	1560	1560	1560

DESCRIPTION

The **PoE CP12** from IOTA is a UL Listed emergency lighting LED battery pack (LED emergency driver) for Power over the Ethernet (PoE) systems, and works in conjunction with a PoE normal lighting LED driver to convert a PoE normal lighting luminaire to an emergency luminaire compliant with NFPA-101. In the event of a power failure, the **PoE CP12** switches to the emergency mode and operates the existing fixture for **90 minutes**. The unit contains a battery, charger, and converter circuit in a single can and is available with different output configurations for individual fixture requirements. The **PoE CP12** will operate an LED array load at **12 watts** with **constant power** at a rated output voltage of **10V-60V**. The Constant Power design maintains the output power to the LED array at 12 watts, resulting in no degradation of emergency illumination for the entire run-time.

SPECIFICATIONS

PSE Ports Required	Two (RJ-45)
<small>(see reverse side for port descriptions and functions)</small>	
Input Voltage (Battery Charger Port)	37Vdc - 57Vdc (48Vdc nom.)
Input Wattage (Battery Charger Port)	4W max.
Compatibility (Battery Charger Port)	IEEE802.3af and IEEE802.3at Standards
Output Voltage ¹	10-60VDC Class 2 Compliant
Output Power	12 Watts (constant)
Emergency Operation	90 minutes
Operating Temp.	0° to 50° C
Battery	High Temp Nickel-Cadmium 24 Hour Recharge 7-10 Year Life Expectancy
Weight	2.7 lbs.
Approval	UL Listed as an LED emergency driver for field installation

¹Max. output voltage in emergency mode is 58.5 VDC with a + tolerance of 1.5 volts



PRODUCT ADVANTAGES

- **Power-over-Ethernet Input**
Provides emergency capability to PoE/IoT luminaires without compromising data integrity
- **Auto-Sensing Class 2 Output**
Auto-adjusting 10-60 VDC output range accommodates a full range of Class 2 forward voltage LED designs
- **Constant Power Performance**
Constant wattage delivery maintains illumination for the full emergency runtime with no degradation
- **Listed for Field or Factory Installation**
UL Listed for both field or factory installation in United States and Canada

FEATURES

- UL 924 Listed, UL Listed and Classified to FTBV
- UL 1310 Certified, Output Class 2 Compliant
- RJ-45 or Hardwired Load Connection options
- Long life high temperature recyclable Ni-Cad battery
- Galvanized steel case
- Includes single-piece TBTS test switch and charge indicator accessory kit
- For use with switched or unswitched fixtures
- **5-Year Warranty.**
- Meets or exceeds all NEC, IBC, and Life Safety Code Emergency Lighting Requirements
- Rated for use in Plenum, Damp Location, Recessed Type IC, and Enclosed and Gasketed Luminaires
- RoHS Compliant

DIMENSIONS

15.6" x 2.8" x 1.2" (mounting center 15.2" x 1.6")

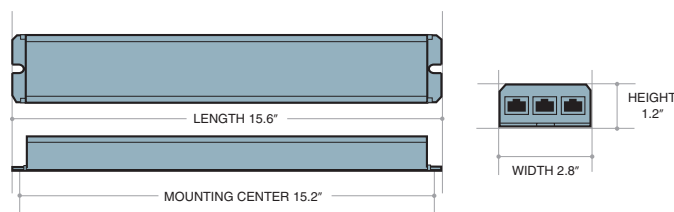

PoE CP12

Power-Over-Ethernet Emergency LED Driver

ORDERING GUIDE

POE

CP12

V1A (Hardwire Connections to Normal Driver and LED Array)

V1B* (RJ-45 Connectors to Normal Driver and LED Array)

Understanding Your IOTA Driver Model:

PoE = IOTA Power-over-Ethernet Emergency LED Driver

CP** = Constant Power Performance at the rated wattage

*Consult IOTA Technical Support for RJ-45 pin connections

PoE CP12 Sample Specification

Supply and install IOTA [Insert 12W model number] Constant Power emergency LED driver system as indicated. The emergency driver shall be designed for [Select "Internal" or "External"] mounting to the luminaire including a self-contained, high-temperature, sealed, maintenance-free nickel cadmium battery rated for a 10-year service life. The unit shall be provided complete with an illuminated push to test switch. The emergency driver system shall be UL class 2 certified in accordance with UL 1310 and shall be UL listed for use in damp locations and in enclosed and gasketed fixtures with a temperature range of 0° to 50° C.

The PoE (Power-over-Ethernet) input shall be compatible with IEEE 802.af & IEEE 802.3at standards. The unit shall be UL Listed Emergency Lighting and Power Equipment, FTBV, Emergency Light-Emitting-Diode Drivers for field installation. Maximum input power of the emergency driver shall be 4 watts.

The charger shall be current limited, temperature compensated, short-circuit protected with reverse polarity protection. A low voltage battery disconnect (LVD) circuit shall be provided and will disconnect the load and circuitry from the battery when it reaches approximately 80 to 85% of its nominal terminal voltage, preventing a non-recoverable, deep-discharge condition. The unit shall achieve a full recharge in 24-hours.

The emergency driver shall accommodate an LED load with a forward voltage requirement ranging from 10 to 60 VDC. The output voltage sensing shall be automatic and instantaneous with a resulting, inversely-proportional current to maintain constant power to the LED array with an output tolerance of +/- 3%. The unit shall supply the rated load for a minimum of 1 1/2 hours. The output power to the LED load during emergency operation shall be held constant 12 watts from minute one throughout the entire emergency run time resulting in no loss or degradation of the light source during emergency operation.

Maximum remote mounting distance of the emergency driver shall be 50-feet.

Emergency Lumen Performance - PoE CP12

Approx. Luminaire Efficacy	Minute 1	Minute 45	Minute 90
100 lm/W	1200	1200	1200
110 lm/W	1320	1320	1320
120 lm/W	1440	1440	1440
130 lm/W	1560	1560	1560



Visit www.iotaengineering.com/cptools to access our on-line CP performance calculator for additional performance data and other specification resources.



The **PoE CP12** is UL Listed and Classified for Field Installation. Refer to the "**CP Series Compatibility and Suitability of Use Guidelines**" addendum for complete project installation requirements.

CONNECTION REFERENCE

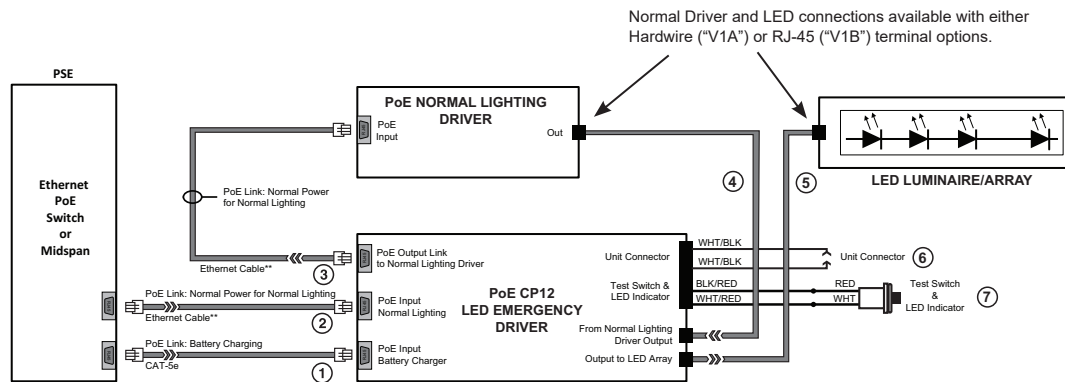

** Use cables as specified by the PoE Normal Lighting Driver manufacturer.

- ① PoE Link segment for Battery charging only.
- ② PoE Link segment for Normal Power for Normal Lighting. Connects to LED Emergency Driver first then passes through directly to Normal Driver.
- ③ Normal Power PoE Link from LED Emergency Driver to Normal Lighting Driver Input.
- ④ Output from PoE Normal Lighting Driver to Emergency Driver.
- ⑤ Output from the LED Emergency Driver to the designated LED Luminaire/Array/Module. Secure connection per NEC 700.12(F).
- ⑥ Unit Connector. Join connector as final step in field installation.
- ⑦ Test Switch with LED indicator.

Warranty: 5-Year Limited Warranty

Complete warranty terms located at www.acuitybrands.com/CustomerResources/Terms_and_conditions.aspx