

R-5HO

INCANDESCENT REMOTE CAPABLE THERMOPLASTIC EMERGENCY UNIT



STANDARD



OPTIONAL



ILLUMINATION

- Two fully adjustable 5.4 watt, glare-free lamp heads.
- Smooth plastic reflector and lens for optimal light distribution.

ELECTRICAL

- Dual 120/277 voltage.
- Charge rate/power "ON" LED indicator light and push-to-test switch for mandated code compliance testing.
- LVD (low voltage disconnect) prevents battery from deep discharge.
- 6V maintenance-free, rechargeable sealed lead acid battery.
- Remote capacity of 11.0 watts standard.
- Internal solid-state transfer switch automatically connects the internal battery to lamp heads for minimum 90-minute emergency illumination.
- Fully automatic solid-state, two rate charger initiates battery charging to recharge a discharged battery in 24 hours.

MOUNTING

- Universal knockout pattern on back plate for wall mount. Snaps into place making internal electrical connections.
- Knockout for conduit applications.

HOUSING

- Injection-molded, engineering grade, 5VA flame retardant, high-impact resistant, thermoplastic in white or black finish.

OPTIONS

- SDT: Self-diagnostic feature performs monthly, biannual, and annual tests to ensure reliable operation and meets electrical and life safety codes.
- USA: Substantial transformation assembly in the U.S. complies with "Assembled in the USA" under the Buy American Act.

WARRANTY / LISTING

- Five year warranty on all electronics and housing. Battery prorated for two years.
- Meets UL924, NFPA 101 Life Safety Code, NEC, OSHA, Local and State Codes.
- UL listed for damp locations (20°C – 40°C).

DIMENSIONS

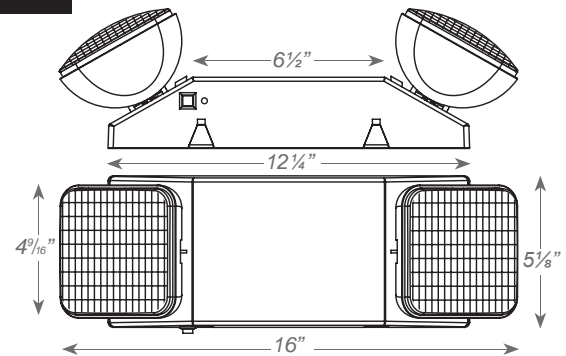

Sample Part Number: R-5HO

ORDERING INFORMATION

Special voltage options available.
Check with your Best Lighting
Representative.

MODEL	HOUSING COLOR		OPTIONS	
R-5HO	(blank)	White	SDT	Self-Diagnostics
	B	Black	USA	Assembled in USA

www.emergency-lighting.com