

Job/Location: _____
 Contractor: _____
 Prepared By: _____

Job Type: _____
 Date: _____

■ The **REL** has PAR36 heads standard. PAR18 (SR) style and MR16 bullet style heads (MRB) are also offered. Multiple lamp options are available including LED.



■ Torsion springs securely hold the **REL** cover in place. This eliminates the need for screws and allows for quick and trouble free installation and general maintenance.

External test switch and monitor LED are standard

■ **Installation:** The **REL** is designed to be fully recessed into a ceiling or wall. Ideal for running remote loads and maintaining an architectural element.

■ **Housing:** Durable 20G steel. White powder coat finish is standard, (other colors optional).

■ specifications: internal

The REL is configured with 120/277VAC input with solid state charging circuitry. Standard features include low voltage disconnect, AC lockout and brownout protection.

■ specifications: external

The REL cabinet is constructed from durable 20 gauge steel. White powder coat finish is standard, (other colors optional). Emergency lighting heads are molded from high impact thermoplastic in a matching color; PAR36 style heads are standard. PAR18 (SR) style heads are optional. MR16 (MRB) are also offered. External test switch and monitor LED are standard.

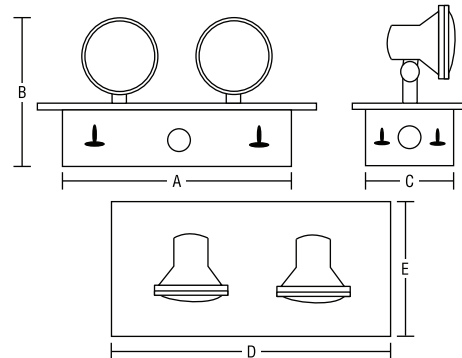

Series	A	B	C	D	E
REL	10.2"	9.5"	8.1"	13"	9.2"
	259mm	241mm	206mm	330mm	234mm

NOTE: Dimension B (see drawing) will vary bases on heads supplied.

■ ordering logic

Model	Volts	Watts Pb-A Battery	Watts Ni-Cd ¹ Battery	Emergency Heads	Lamps ²	Options
REL	6 (6V)	12 (6V)	22 (6V)	0 (no heads)	(see lamp chart)	SD (self diagnostics)
	12 (12V)	18 (6V)	42 (6V,12V)	2 (2 PAR36 heads)		NC (nicad battery)
		27 (6V,12V)		2SR (2 PAR18 heads)		TD ³ (time delay relay)
		36 (6V,12V)		2MRB (2 MR16 Bullet heads)		BL (black housing)

EXAMPLE: REL-6-27-2-6VSBH-8W-SD
 DESCRIPTION: REL Emergency Unit, 6VDC, 27 Watts, sealed lead battery, two PAR36 heads, 8 watt sealed beam halogen lamps, self diagnostics

¹Nickel-cadmium. Must select NC from options when selecting Ni-Cd.

²Specify desired lamp type and wattage from lamp selection chart

³Must specify 5, 10 or 20 mins and AC Voltage (10 mins standard)

■ specifications: electrical

BATTERY: The REL is designed with a maintenance free, sealed valve regulated lead acid battery that provides a minimum emergency duration of 90 minutes. Optional nickel cadmium batteries are available. Recharge time of the battery is twenty-four hours. The maximum working temperature is 45° C. The minimum working temperature is 10° C.

CIRCUIT: The REL utilizes a high-efficiency two stage charger providing precise float voltage control with low voltage disconnect protection. The charger also has brownout and short circuit protection. Charger status is easily determined via a dual diagnostic LED display which indicates AC/ON and High Charge. All components used in the circuitry are temperature compensated. An external push button test switch allows maintenance personnel to quickly determine the operational status of the unit and lamp load.

■ specifications: mechanical

Torsion springs firmly hold the REL cover in place allowing for easy installation and maintenance. Remote lamp loads are connected to the emergency power supply with sturdy terminal connectors. These connectors allow for a large gauge of wire to be used, increasing the flexibility of installation.

■ specifications: self diagnostics

The Mule Autotest system performs one 5 minute discharge test monthly. Every 6 months two 90 minute discharge tests are performed. This tests both full battery capacity and recharge capability, as required by the fire code. The information is communicated simply and intuitively to maintenance personnel via a single multi-color LED. When the LED is green the unit is functioning normally. If the LED is yellow there is a malfunction in the lamp circuit. A red LED indicates a battery or charger problem, including low battery capacity. The Mule Autotest system also includes 0, 5, 10 or 20 minute time Autotest delay function to allow HID lighting restrike.

- Red: Battery or Circuit Malfunction
- Yellow: Lamp Malfunctioning
- Green: Normal Operation

■ warranty

The REL comes with a 3-year factory warranty. Lamps are not covered under the warranty. Deliberate damage, misuse, improper installation effectively cancel the warranty.

■ lamp selection

	6V	12V
Incandescent	5.4, 7, 9, 12W (18W - PAR36 only)	9, 12, 18W (25W - PAR36 Only)
Halogen (H)	8, 10, 12, 20W	8, 12, 20, 35W (55W PAR36 only)
Sealed Beam Tungsten (SB)	12, 18, 25, 30W	12, 18, 25, 30, 35W
Sealed Beam Halogen (SBH)	8, 12, 20W	8, 12, 30W
MR16 Halogen (MRB)	10W	10, 12, 20, 35, 50W
MR16 LED ^[1]	5W, 7W	5W, 7W

[1]NOTE: LED lamps can be installed in SR &MRB heads only.

■ model rating guide

Model	Input Voltage	Wattage			
		90min	120min	180min	240min
REL-6-12	6	12	9	6	5
REL-6-18	6	18	12	N/A	N/A
REL-6-22	6	22	17	11	9
REL-6-27	6	27	20	N/A	N/A
REL-6-36	6	36	27	18	14
REL-6-42	6	42	32	21	16
REL-12-27	12	27	20	14	10
REL-12-36	12	36	24	18	12
REL-12-42	12	42	32	21	16